

# **TVLR** *SERIES*

**Railgates By THIEMAN**

## **TVLR 30, 30A OWNER'S MANUAL/PARTS LIST**

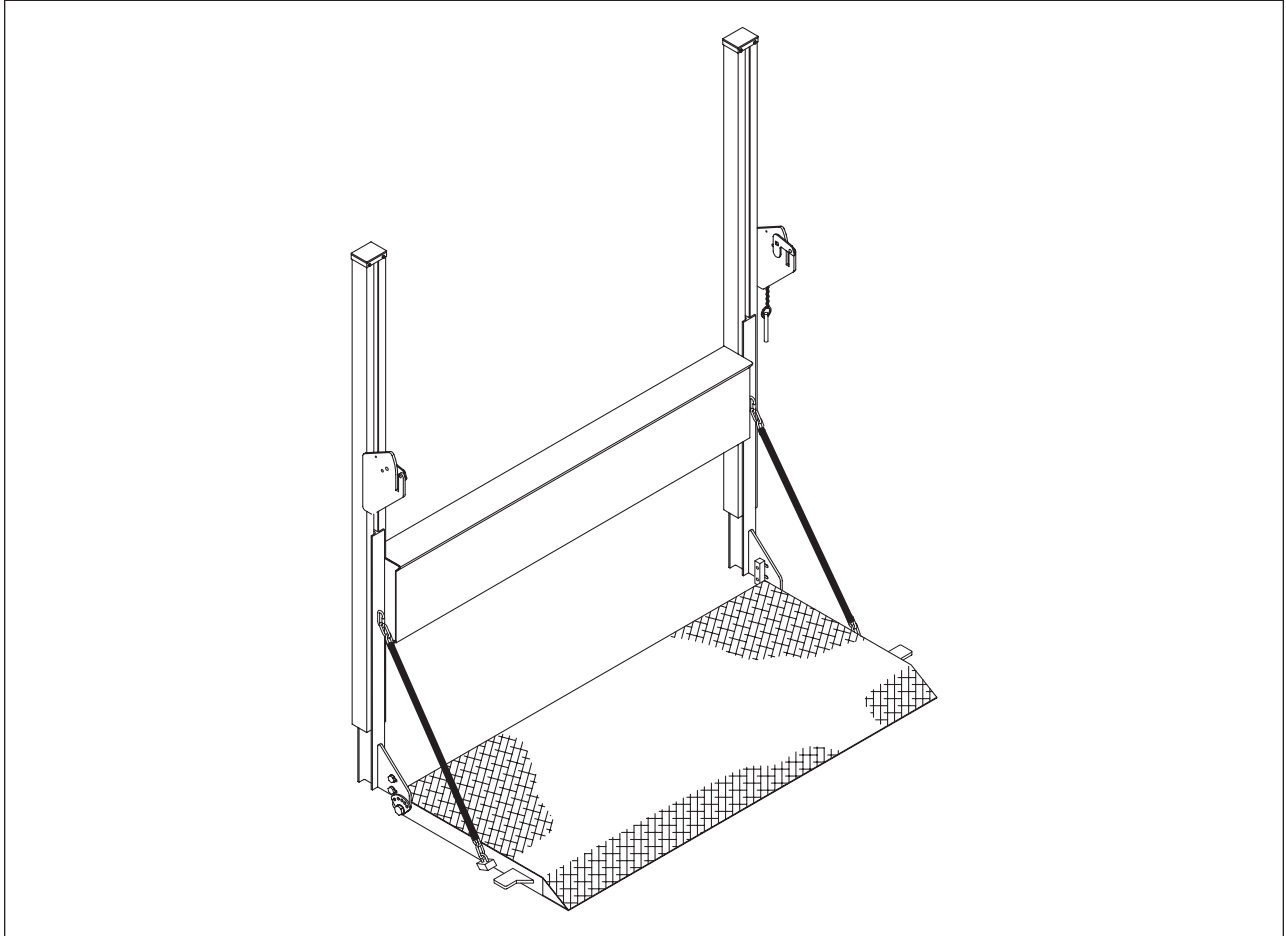

**IMPORTANT! KEEP IN VEHICLE!**

**PLEASE READ AND UNDERSTAND THE CONTENTS OF THIS  
MANUAL BEFORE OPERATING THE EQUIPMENT.**

**THIEMAN**  
TAILGATES, INC.

600 East Wayne Street  
Celina, Ohio 45822

Phone: 419-586-7727 Fax: 419-586-9724  
[www.thiemantailgates.com](http://www.thiemantailgates.com)

**NTEA**  
THE ASSOCIATION FOR THE WORK TRUCK INDUSTRY  
MEMBER

# TABLE OF CONTENTS

	PAGE
PARTS ORDERING PROCEDURE.....	2
WARNINGS.....	3
OPERATING INSTRUCTIONS.....	5
MAINTENANCE GUIDE.....	6
SEMI-ANNUAL INSPECTION.....	9
INSPECTION AND LOCATION OF DECALS.....	10
MAIN FRAME ASSEMBLY.....	11,12
LIFTING CHAIN ASSEMBLY.....	13
SLIDER ASSEMBLY.....	14
STEEL PLATFORM ASSEMBLY.....	15
ALUMINUM PLATFORM ASSEMBLY.....	16
PLATFORM CHAIN, SPRING & DAMPER ASSEMBLES.....	17
HOUSING COVERS.....	18-19
ELECTRICAL PICTORIAL.....	20
CAM CLOSE/2 PC PLATFORM 3 FINGERED HINGE.....	21
TROUBLESHOOTING GUIDE.....	22-25

## FOR YOUR RECORDS

Model No. \_\_\_\_\_ Date Purchased \_\_\_\_\_

Serial No. \_\_\_\_\_

**NOTE: When Ordering Parts Be Sure To Include This Information!**

Your Thieman Tailgate is constructed of top quality material and is warranted to be free from defects in material and workmanship under normal use. With routine maintenance and proper operation this liftgate will provide long lasting service and dependability.

## PARTS ORDERING PROCEDURE

When ordering parts, please include all the information asked below. If this information is not available, a photo of the required part MAY help Thieman identify and deliver the needed part to you.

### THE FOLLOWING INFORMATION MUST BE INCLUDED:

1. Serial Number - Thieman TVLR liftgate serial numbers can be found on the tag located on the inner or outer side of the curb side frame rail.
2. Model number and capacity
3. Platform size and material - steel or aluminum
4. Part number
5. Description
6. Quantity required

## WARNING!

The following list of warnings is to be read before operating the TVLR series liftgate.

- +DO NOT operate this Thieman liftgate without the Owner's Manual for this model present on the vehicle and without all decals present and legible, as guides for proper liftgate operation and maintenance. (see the "Inspection and Location of Decals" section of this manual. For replacement Owner's Manuals, decals, etc. call Thieman at 419-586-7727. For the latest manuals and warnings for each liftgate, visit our website at [www.thiemantailgates.com](http://www.thiemantailgates.com). Note: manuals and warnings update regularly.
- +DO NOT operate this liftgate unless you have been properly instructed and have read and understood the Owner's Manual, operating instructions and all decals. Improper operation of this lift may result in serious personal injury and/or damage to the liftgate.
- +The vehicle must be securely and properly braked on level ground before using the liftgate.
- +All protective covers and guards must be in place before operating the liftgate.
- +Before using liftgate, check for signs of improper maintenance or damage (unusual noises, vibrations, fails to operate freely, missing hardware, cracked welds...etc). DO NOT use the lift if these are evident. Only an authorized Thieman distributor is qualified to do repairs on the liftgate. DO NOT attempt to do your own repairs or modify this liftgate. Altering this product will void all warranties and may damage the liftgate or even cause serious injury. If any repairs, adjustments, or maintenance not covered in this manual are required, contact your nearest Thieman distributor or call Thieman at 419-586-7727.
- +THIS IS NOT A PERSONNEL LIFT. Because of the pinch point between the platform and the truck, fall hazards, unstable loads, etc., riding the lift may cause severe personal injury or death. ALWAYS stay clear of the liftgate when in operation. Do NOT ride the liftgate.
- +This liftgate is intended for the use of loading and unloading cargo only, it is not to be used for anything other than this.
- +DO NOT OVERLOAD THE LIFTGATE. Each liftgate has a specific maximum capacity for lifting and lowering. The standard maximum rated capacities of the TVLR series liftgates differs with each model as follows:

TVLR 30 - 3000 lbs. Maximum Load

NOTE: Special options can lower the maximum rated capacities below those shown above. Be certain you know what the maximum rated capacity is for your particular liftgate.

- +NEVER off-center the load on the platform, from side to side or away from truck as this may overload the liftgate. The center of weight of the load should NEVER be placed beyond the center of the platform load surface, away from truck. Loads should be placed close to platform edge nearest truck. See figure 1.
- +NEVER allow any part of the load to extend beyond the edges of the platform's flat load surface.
- +NEVER allow any part of the load to extend over or on, the tapered ramp portion of the platform unless the platform is lowered completely to the ground and the ramp is supported by the ground.
- +NEVER lift or lower unstable loads.
- +NEVER operate liftgate if platform load surface is slippery.
- +Make certain that the area below the platform is clear before and at all times during operation of the liftgate.
- +Load and unload the platform from the rear and not from the side of the platform. Never remove the platform support chains to load or unload the platform.
- +Never operate lift trucks on or over any part of the platform.
- +Follow the maintenance guide as outlined in this manual.
- +NEVER move vehicle unless platform is properly stowed and power is off. Locking cams must be properly pinned before transit.
- +Any time the vehicle is washed, this liftgate MUST be inspected to MAKE SURE all parts are properly lubricated and have the appropriate protectants. Failure to replace lubricants and protectants after washing the vehicle, may lead to improper operation of the liftgate, accelerated corrosion, and possible component failure.

## WARNING: POSITION LOADS PROPERLY ON PLATFORM

NEVER off-center the load on the platform, from side to side or away from truck as this may overload the liftgate. The center of weight of the load should NEVER be placed beyond the center of the platform load surface, away from truck. Loads should be placed close to the platform edge nearest truck. If a load is not uniformly distributed, then the heaviest portion should be closest to the edge of the platform nearest the truck. NEVER allow any part of the load to extend beyond the edges of the platform's flat load surface. NEVER allow any part of the load to extend over or on, the tapered ramp portion of the platform unless the platform is lowered completely to the ground and the ramp is supported by the ground.

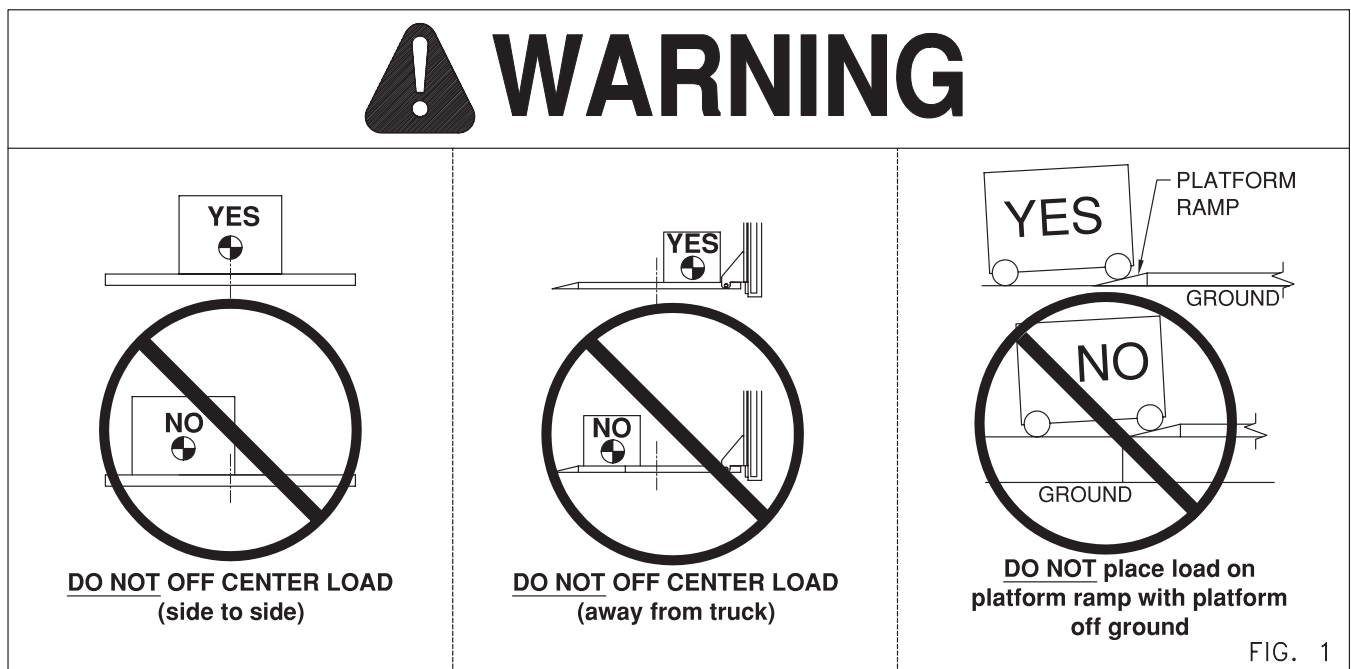

**THERMAL DATA:** To avoid overheating the motor do not operate this unit for more than 5 cycles/10 minutes with the maximum load. The motor then must be allowed to completely cool down to ambient temperature before cycling the lift again. This unit also has a 11% duty cycle, which means the liftgate can be cycled no more than 2 cycles/10 minutes constantly with a maximum load.

# OPERATING INSTRUCTIONS

## CAUTION:

Be sure to operate liftgate at a safe distance and never improperly load platform as this may cause personal injury or damage to the liftgate.

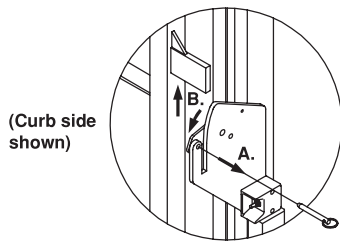

## 1. UNLOCK

- A. Remove curb side AND street side latch pins from resting plates.
- B. Raise liftgate until locking cams rotate back down

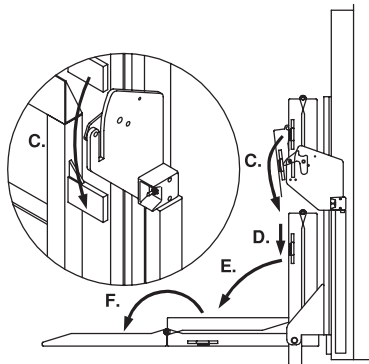

## 2. UNFOLD

- C. Lower liftgate, so guide plates ride over cams, and are below resting plates
- D. Lower liftgate to a comfortable height to unfold the platform.
- E. Manually unfold the platform to horizontal position
- F. Unfold secondary platform sections if so equipped.

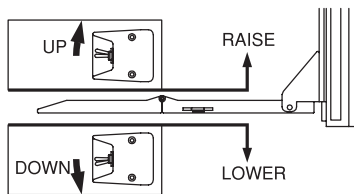

## 3. RAISE OR LOWER

- G. Use toggle switch or other supplied control to raise or lower liftgate.

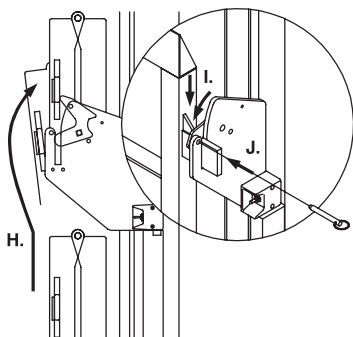

## 4. STORE FOR TRANSIT

- H. Reverse Step 2 above. Fold platform to vertical position and raise folded liftgate until locking cams on resting plates are rotated up and stowage slot in resting plates are exposed.
- I. Lower liftgate until locking cams rotate back down.
- J. Reinsert curb side AND street side latch pins into holes of resting plates and locking cams.

# MAINTENANCE GUIDE

The following inspection and maintenance operations should be performed at the recommended intervals of anytime the liftgate shows signs of abuse and improper or abnormal operation.

## MONTHLY INSPECTION AND MAINTENANCE

Operate the liftgate throughout its entire operational cycle and check the following:

1. Check that there are no unusual noises or vibrations.
2. Check that the platform is level front to back and side to side when raised to bed height. If front to back adjustments are necessary, this can be done by adjusting nuts (A) on U-bolt (B) on platform block (C). See figure 2. If side to side adjustments are necessary, this can be done by adjusting nuts (D), nylon insert locknuts (E), and lockwashers (F) on tension rods (G) on anchor bracket (H). See figure 2.

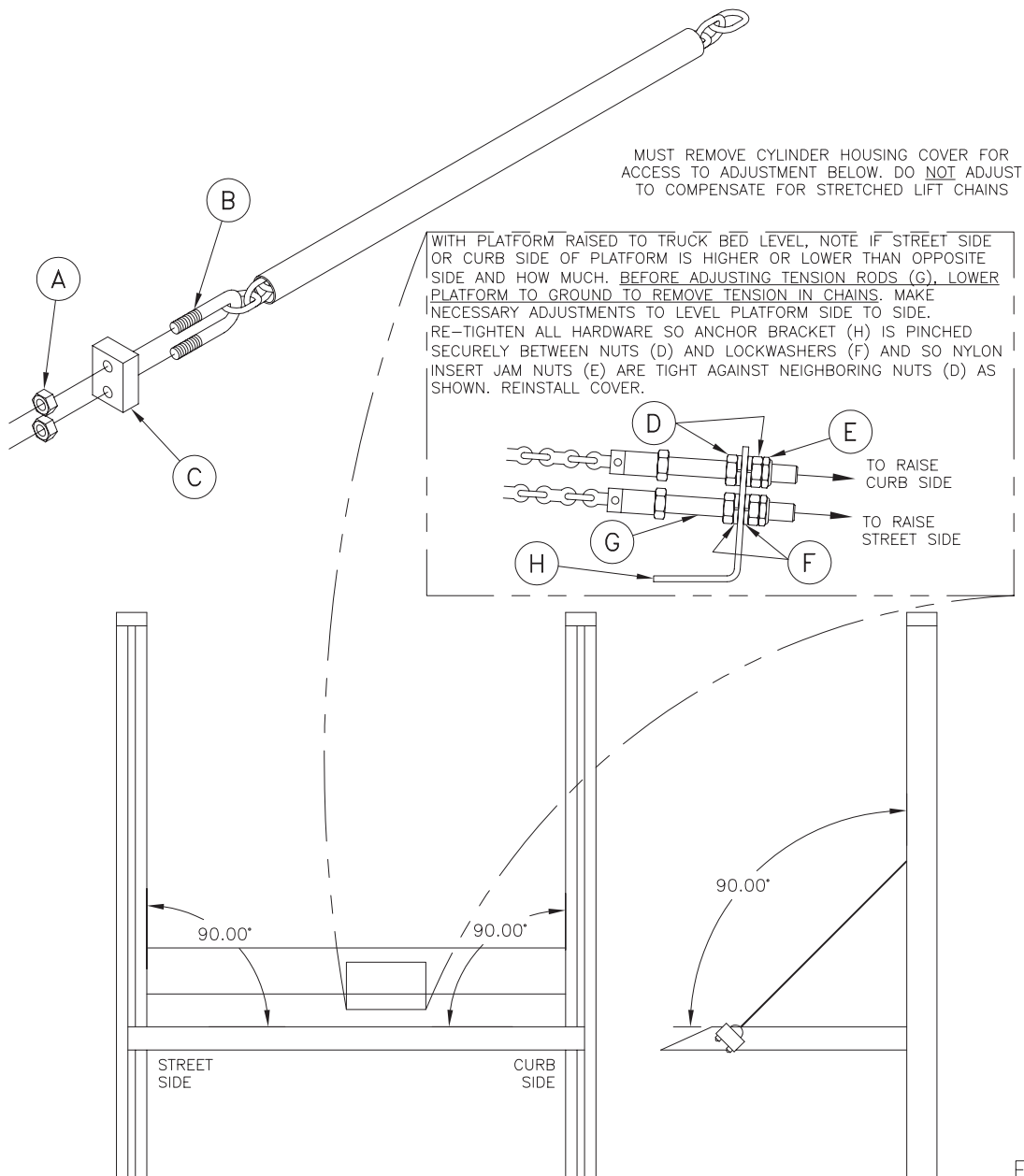

3. Check for apparent damage to the liftgate such as bent or distorted members, any cracked welds, which may have resulted from overloading or abuse.
4. Check for any excessive wear in the following pivot areas (Note: For bushed pivots, if the gap between pin and bushing exceeds 1/32 of an inch, the bushing should be replaced. For pivots without bushings, replace worn components if gap between pin and pivot exceeds 1/32 of an inch. Refer to parts breakdowns in this manual):
  - A. Cylinder pin.
  - B. Adjustment bracket, pin retainer and bushings joining sliders to platform.
  - C. Slider roller assembly (roller and bearing) and pins.
  - D. Nylon wear pads on slider.
  - E. Pusher wear pad.
  - F. Chain roller assemblies, bushings and pins.
  - G. Platform support chains and chain anchor points.
  - H. Lift chains-replace if stretched or non-flexible.
  - I. Platform hinge pins, and bushings (two-piece platform only).
5. Check that all platform pivot pins are in place and retained by their proper retainers. The street side platform pivot pin (Adjusting Bracket) is bolted to the slider pivot with a 3/8 bolt. There is a formed retainer welded to the street side of the platform, which wraps around the slotted plate of the Adjusting Bracket in the stored position and holds the street side platform pivot pin in the platform pivot. The curb side platform pivot pin (Pin Retainer) is bolted to the slider pivot with a 3/8 bolt. There is a Stop, which is bolted to the curb side of the platform with two 1/4 inch screws which holds curb side platform pivot pin in the platform pivot.
6. Check that all protective covers and guards are properly in place and secured.
7. Check painted finish, if in poor condition, repaint. Mask any rail opening to avoid overspray. Any rusted parts should be replaced.
8. Check condition of non-painted parts, replace if corrosion exists.
9. Check for oil leaks in these areas:
  - A. Lift cylinder
  - B. Hydraulic hose - replace if it shows signs of wear or cracking.
  - C. Hydraulic fittings - tighten or replace as may be required to stop leakage.
10. Check the oil level in the hydraulic reservoir located in the cylinder housing. With the platform open and at ground level, the oil should be within 1/2 inch from the top of the reservoir. See chart below.

<b>HYDRAULIC FLUID CHART</b>	
Temperature Range	Acceptable Fluids
-75° F to 165° F	Exxon Unavis J-26
-20° F to 130° F	Dexron III Exxon Superflo ATF Shell Spirax S3 ATF MD3
-50° F to 80° F	Shell Aero Fluid 4 Mobil Aero HFA Exxon Unavis J-13 MIL H-5606

11. Check that all wiring and battery cable connections are tight and free of corrosion.

12. Lubrication of the TVLR series gate should be as follows for all user conditions.

Area of Tailgate	Type of Lubrication	*Frequency
Vertical Rails	SAE 10 to SAE 20 oil	50 cycles
Lift Chain	SAE 10 to SAE 20 oil	100 cycles
Chain Anchor Links	SAE 10 to SAE 20 oil	100 cycles
Locking Cams	SAE 10 to SAE 20 oil	100 cycles



# ATTENTION

---

## WEEKLY LUBRICATION REQUIRED

LUBRICATION OF RAILS IS REQUIRED EVERY WEEK OR EVERY 50 CYCLES, WHICHEVER COMES FIRST.

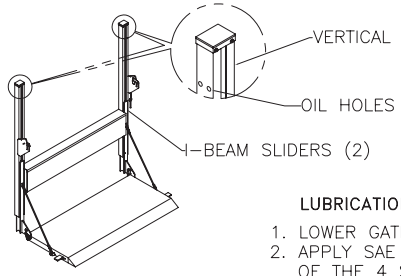

VERTICAL RAILS (2)

OIL HOLES (4)

BEAM SLIDERS (2)

VERTICAL RAIL CROSS-SECTION  
(4 SURFACES TO OIL PER RAIL)

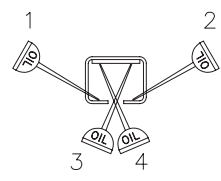

**LUBRICATION INSTRUCTIONS**

1. LOWER GATE TO THE GROUND.
2. APPLY SAE 10W OR 20W OIL AT THE TOP OF EACH OF THE 4 SURFACES SHOWN ON EACH VERTICAL RAIL USING OIL HOLES IF NECESSARY.
3. LET OIL RUN DOWN RAILS TO SLIDERS.
4. CYCLE LIFTGATE A FEW TIMES FROM FULLY LOWERED TO FULLY RAISED. OIL MUST BE EVENLY SPREAD ON ALL 4 SURFACES SHOWN OVER THE ENTIRE RAIL.



\*NOTE: TVLR gates which see less than 50 cycles per week must be lubricated in the areas listed above no less than once a week. Once lubricated, run the gate up and down through one complete cycle to spread lubricant more evenly.

13. Check the pump relief pressure and also the motor amperage at this pressure. These values should be as follows:

Model	Max Amp Draw	Relief Pressure (psi)
TVLR30	245	2750

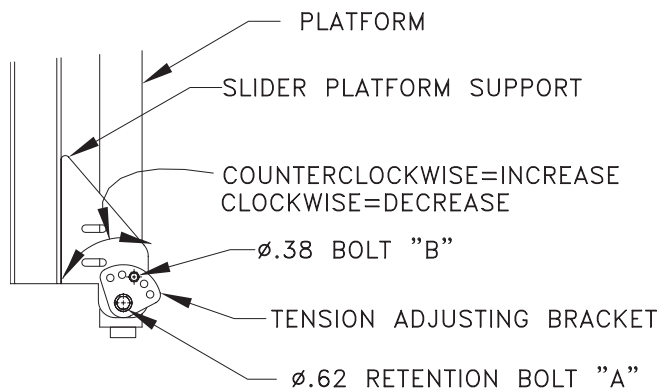
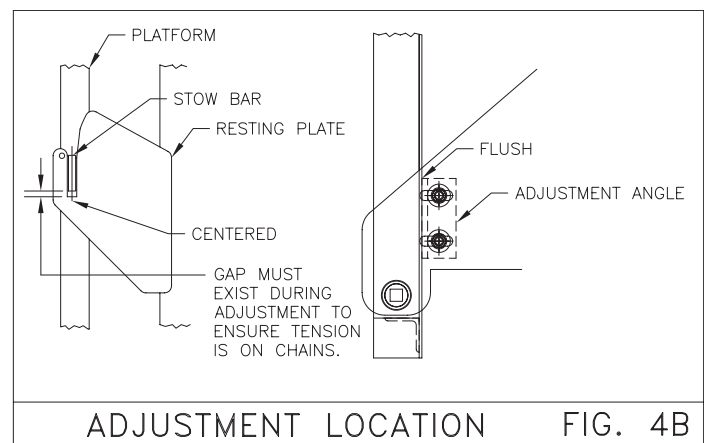
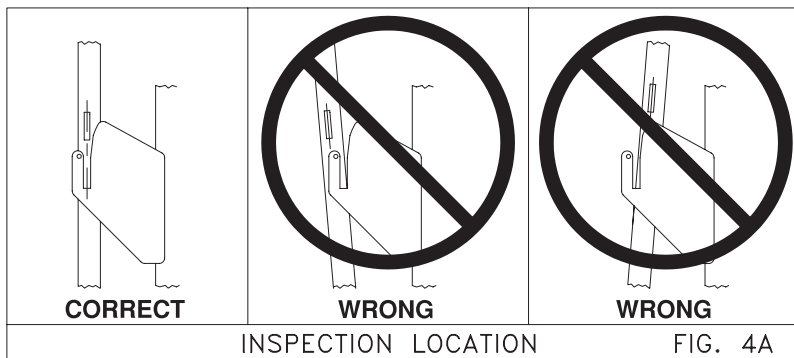

FIG. 3

14. Torsion bar adjustment (See figure 3).
  - A. Place platform in stowed (vertical) position.
  - B. Remove 5/8" diameter bolt (A) from center of tension adjusting bracket.
  - C. Place 1/2" square breaker bar in the square hole of the adjusting bracket pin.
  - D. Turn breaker bar counterclockwise to relieve tension on 3/8" diameter bolt (B) and remove it from the bracket.
  - E. To increase tension, rotate bracket counterclockwise until desired tension is reached. Line up hole in bracket to hole in slider platform support and replace bolt (B).

15. Set adjustment angles on either side of liftgate to hold platform vertical such that the stow bars on platform are aligned with the resting plate slots. Inspect alignment with stow bars raised completely out of resting plate slots (See figure 4A). If they are out of alignment, put the platform in the stored position. Raise platform slightly, so that stow bars are not sitting on the bottom of the resting plate slot, so there is tension in chains (See figure 4B). Then, unloosen screws on the adjustment angles and move angles so they are tight against the vertical platform. Once angles are adjusted, tighten screws. Be sure to do this for both sides. Repeat inspection of stow bar alignment and readjust if necessary. Failure to keep stow bars aligned with resting plate slots can result in excessive wear of stow bars and resting plates.



### **Semi-Annual Inspection**

1. Perform the procedures outlined in the “Monthly Inspection and Maintenance.”
2. Inspect pump motor by:
  - A. Disconnecting battery cable
  - B. Remove motor end cover
  - C. Examine the armature brushes for wear. (Brushes should be replaced if they are less than 1/8” long).
  - D. Clean all residue out from inside of the motor housing.
  - E. Apply several drops of light weight machine oil to the armature shaft bearing in the motor end cover and reassemble the motor end cover.
3. If the hydraulic oil in the reservoir is dirty:
  - A. Unfold platform and lower platform to the ground so the cylinder is fully retracted.
  - B. Drain the oil from the hydraulic system and flush the entire system.
  - C. Remove the reservoir from the pump and clean the suction line filter. Also clean out any contaminants from the reservoir. Remount the reservoir when completed.
  - D. Replace the oil as outlined in Section 10 under Monthly Maintenance and Inspection.

# INSPECTION AND LOCATION OF DECALS

Inspect all decals listed below to be certain that they are in the proper location and they are legible.

**All decals must be in place and legible or all warranties are void!**

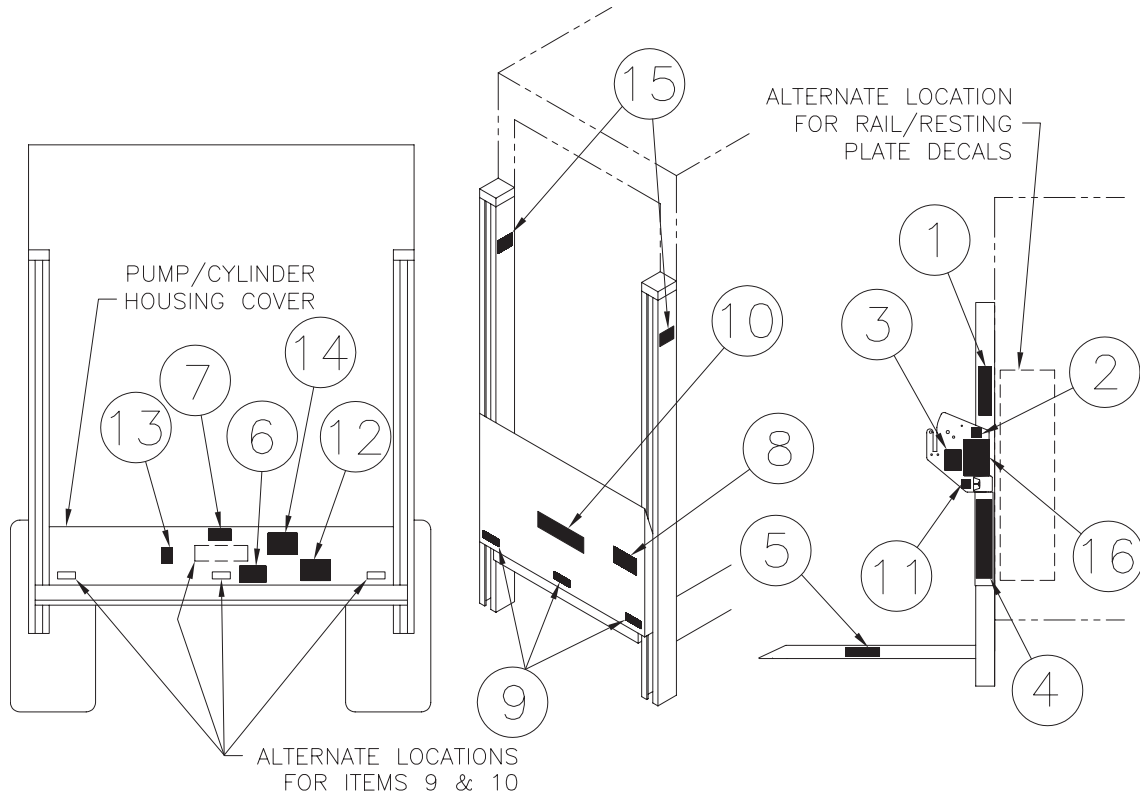

Item	Part Name	Part Number
1	Warning Decal-center load	4682
2	Fast Idle Decal	4650150
3	Danger Decal-no riding	4609
4	Operating Decal	4650780
5	Capacity Decal 3000#	4650120
6	Caution Decal-pinch point	4650790
7	Caution Decal-cover	4650760
8	Caution Decal-working area	4650770
9	Reflector(3)	5705
10	Thieman Nameplate	4650801
11	Toggle Switch Decal(1)	4650820
12	Wiring Decal	4617
13	Warning Decal-high pressure	4620
14	Lubrication Decal	4662
15	Lube Location Decal(4)	4663
16	Urgent Warning Decal	4681

# MAIN FRAME ASSEMBLY

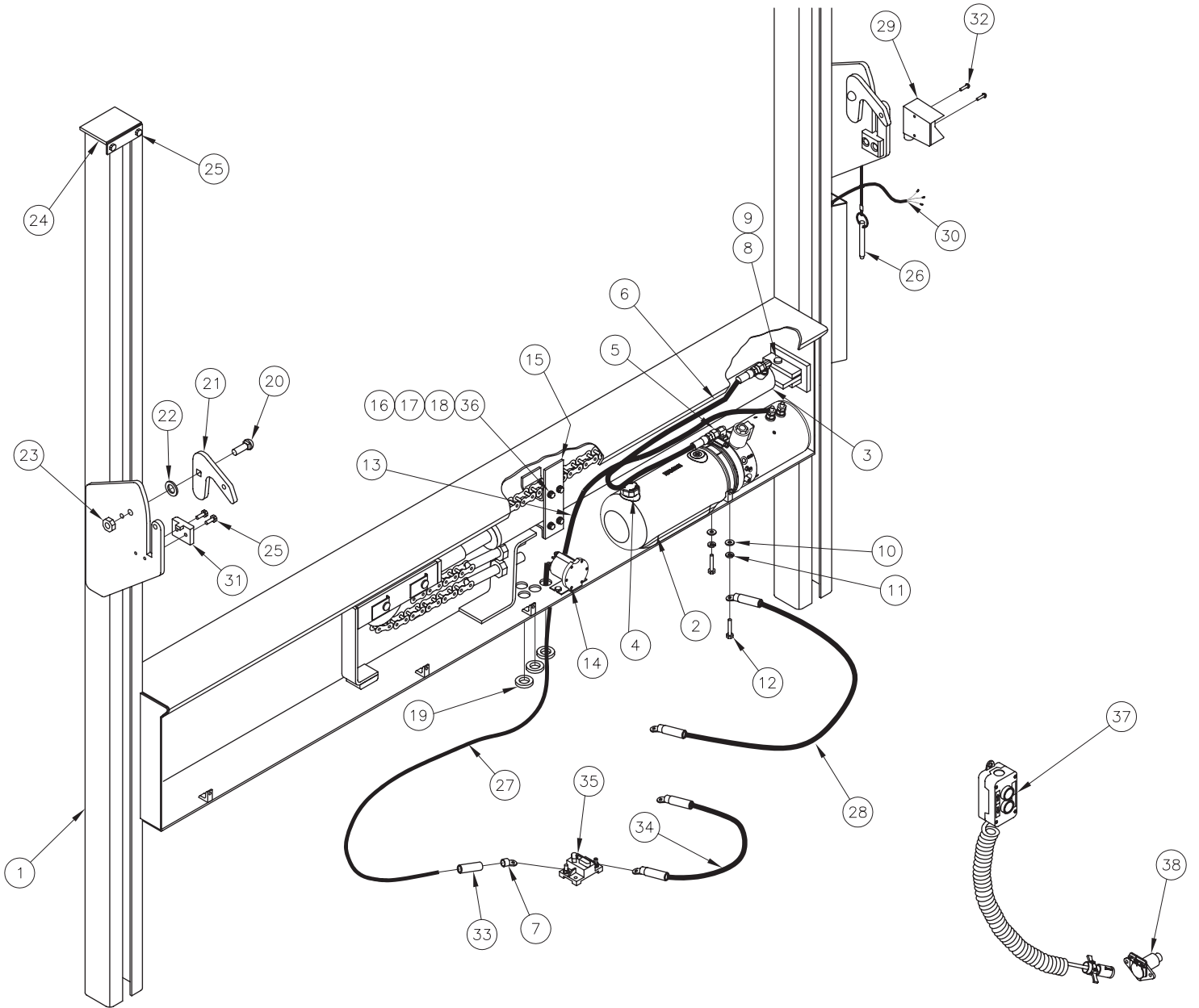

Item	Part Number	Description	Qty.	
			30	30A
1	31770-001	Main frame 80(56"BH)	1	
1	31770-002	Main frame 90(56"BH)	1	
1	31770-003	Main frame 95(56"BH)	1	
1	31770-004	Main frame 100(56"BH)	1	
1	31770-005	Main frame 80(46"BH)		1
1	31770-006	Main frame 90(46"BH)		1
1	31770-007	Main frame 95(46"BH)		1
1	31770-008	Main frame 100(46"BH)		1
2	4474	Power unit	1	1
3	42005	Cylinder assembly	1	1
3	42016	Cylinder assembly (80W)	1	1
4	4420409	Breather cap	1	1
5	4930-001	MJ-MAORB 90°	1	1
6	4951-002	.25 Hose assembly	1	1
7	4350	Cable Lug #2	1	1
8	8101-001	Clevis pin	1	1
9	5700022	Hairpin cotter	1	1
10	8120388	.38 Flatwasher	2	2
11	8120382	.38 Lockwasher	2	2
12	8180126	.38 x 1.50 Screw	2	2
13	4318-002	Battery cable	1	1
14	4477	Solenoid	1	1
15	31558	Cylinder Retainer Weld	1	1
16	8180022	.25 x 1 Screw	4	4
17	8120380	.25 Lockwasher	4	4
18	8120375	.25 Nut	4	4
19	5701960	Grommet	3	3
20	8456922	.50 x 1.50 carriage bolt	2	2
21	2103160	Locking cam	2	2
22	8120396	.50 Flatwasher	2	2
23	8103-021	.50 Lock nut	2	2
24	31765	Roller housing weld	2	2
25	5793010	.25 x .75 Screw	8	8
26	3109140	Latch cable assembly	2	2
27	4300030	Battery cable 25'	1	1
28	4318-003	Battery Cable #2 x 5'	1	1
29	31447	Toggle switch Asm	1	1
30	4301290	Wiring harness	1	1
31	5791	Resting Plate Pad	2	2
32	8111-005	Screw #10 x .75	2	2
33	4319-002	Heat Shrink	1	1
34	4318-001	Battery Cable #2 x 2'	1	1
35	4301770	Circuit Breaker	1	1
36	8120386	Flat Washer	4	4
37	4309	Pendant Control	1	1
38	4301342	Receptacle	1	1

# LIFTING CHAIN ASSEMBLY

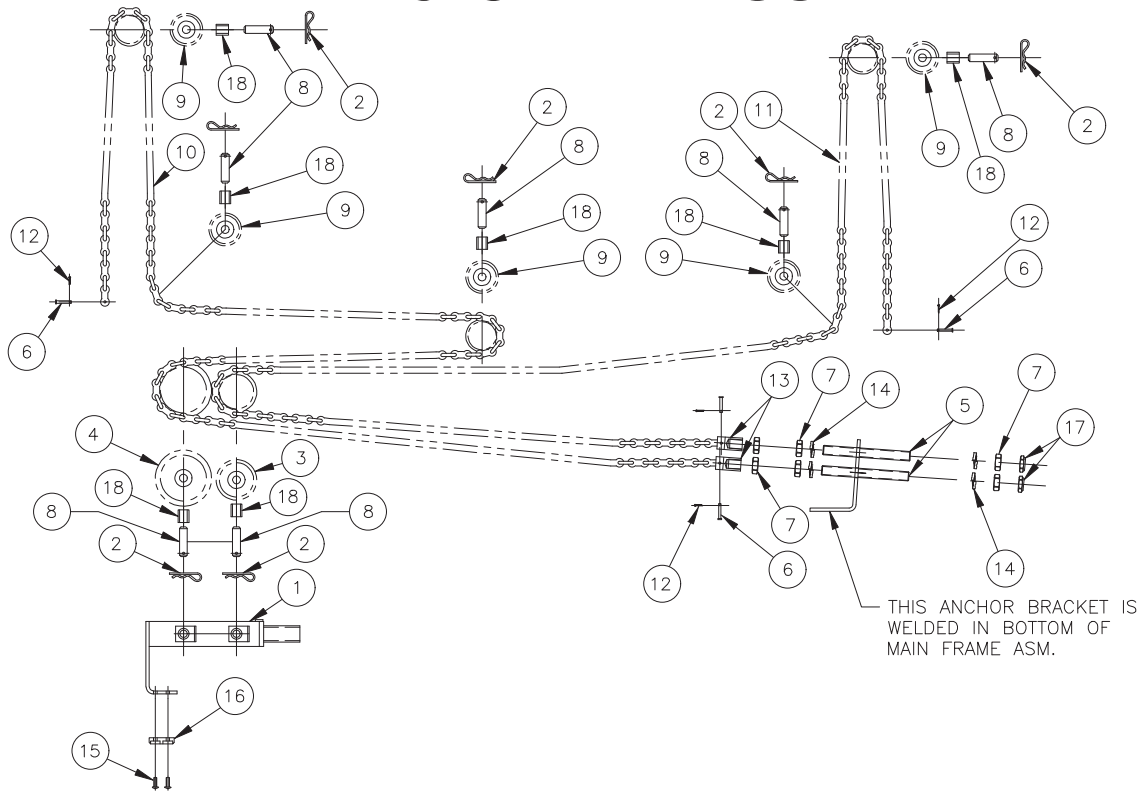

Item	Part Number	Description	Qty.	
			30	30A
1	3109576	Pusher Weld	1	1
2	5700022	Hairpin Cotter	7	7
3	31213-002	3.25 Chain Roller Asm (inc item 18)	1	1
4	31213-003	4.50 Chain Roller Asm (inc item 18)	1	1
5	5084-001	Tension Rod	2	2
6	2502100	Chain Anchor Pin	4	4
7	8219758	.75 Jam Nut	6	6
8	5067	Pin	7	7
9	31213-001	2.63 Chain Roller Asm (inc item 18)	5	5
10	4107-004	Chain SS 90 (56" BH)	1	
10	4107-005	Chain SS 95 (56" BH)	1	
10	4107-006	Chain SS 100 (56" BH)	1	
10	4107-010	Chain SS 90 (46" BH)		1
10	4107-011	Chain SS 95 (46" BH)		1
10	4107-012	Chain SS 100 (46" BH)		1
10	4107-002	Chain SS 80 (56" BH)	1	
10	4107-008	Chain SS 80 (46" BH)		1
11	4107-001	Chain CS 80 (56" BH)	1	
11	4107-007	Chain CS 80 (46" BH)		1
11	4107-003	Chain CS 90,95,100 (56" BH)	1	
11	4107-009	Chain CS 90,95,100 (48" BH)		1
12	8116-001	Cotter Pin	4	4
13	2350001	Chain Anchor Housing	2	2
14	8106-005	.75 Lockwasher	4	4
15	8449646	Self Tapping Screw	2	2
16	5703	Wear Pad	1	1
17	8103-029	Hex Jam, Nylon Locknut .75	2	2
18	5504-008	Bushing	7	7

# SLIDER ASSEMBLY

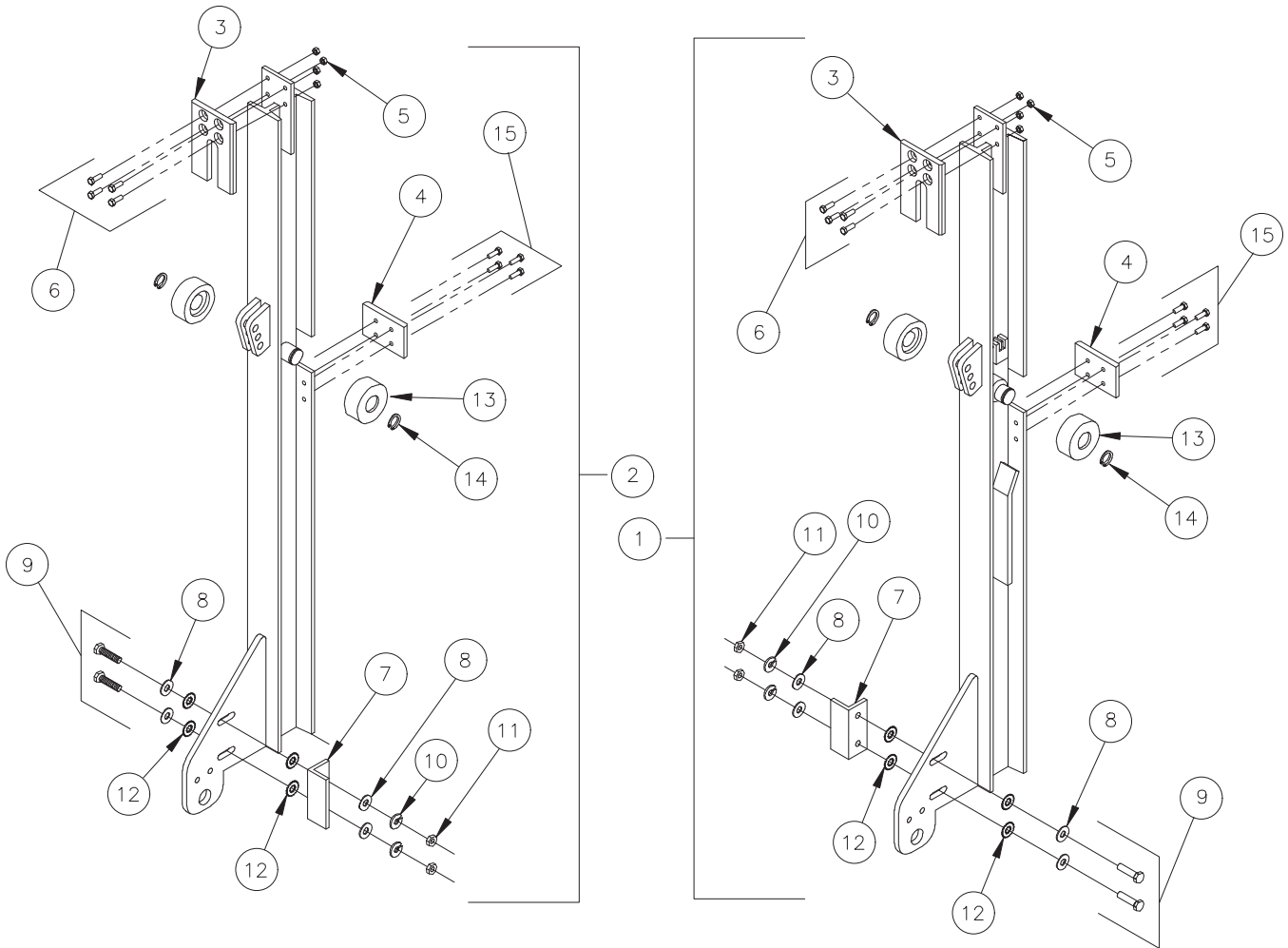

Item	Part Number	Description	Qty.
1	31772-001	Slider Asm RH	1
1	31772-002	Slider Asm RH-Spring	1
2	1773-001	Slider Asm LH	1
2	1773-002	Slider Asm LH-Spring	1
3	5781	Front Wear Pad	2
4	5796	Rear Wear Pad	2
5	8103-019	.25 Locknut	8
6	8109-012	Screw .25 x .75	8
7	2013	Adjustment Angle	2
8	8120388	.38 Flatwasher	8
9	8180126	.38-16 x 1.50 Screw	4
10	8120382	Lockwasher .38	4
11	8120377	.38-16 Nut	4
12	8106-016	.38 Int/Ext Tooth Lockwasher	8
13	31762	Roller Asm	4
14	5781016	Retaining ring	4
15	8449646	Self Screw Tap .25-20	8

+Used with aluminum platforms requiring a spring assembly.

# STEEL PLATFORM ASSEMBLY

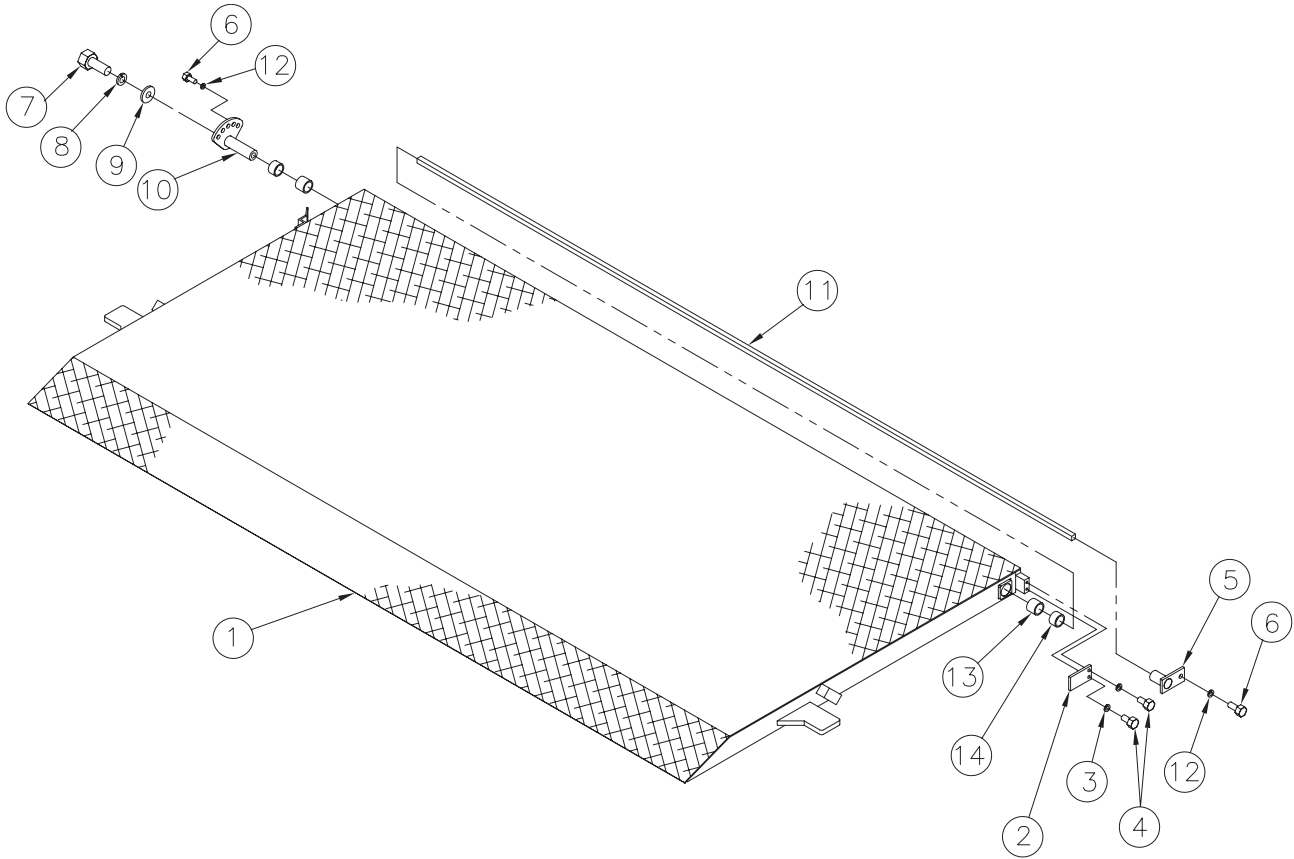

Item	Part Number	Description	Qty.
1	3408-001	7530 Platform	1
1	3408-002	7536 Platform	1
1	3408-003	7542 Platform	1
1	3408-004	8530 Platform	1
1	3408-005	8536 Platform	1
1	3408-006	8542 Platform (see note 1)	1
1	3408-007	9030 Platform	1
1	3408-008	9036 Platform	1
1	3408-009	9042 Platform (see note 1)	1
1	3408-010	9530 Platform	1
1	3408-011	9536 Platform	1
1	3408-012	9542 Platform (see note 1)	1

Item	Part Number	Description	Qty.
2	2329	Stop	1
3	8120380	.25 Lockwasher	2
4	8180022	.25 x 1.00 Screw	2
5	3199	Pin retainer	1
6	8180120	.38 x .75 Screw	2
7	8271713	.62 x 1.00 Screw	1
8	8121574	.62 Lockwasher	1
9	8130999	.62 Flatwasher	1
10	3108980	Adjusting bracket	1
11	5101-001	Torsion bar 85" platform	1
11	5101-002	Torsion bar 90" platform	1
11	5101-003	Torsion bar 95" platform	1
11	5101-004	Torsion bar 75" platform	1
12	8120382	.38 Lockwasher	2
13	5504-005	Bushing	2
14	5504-001	Bushing	2

**Notes:**

1. Requires one spring assembly and appropriate RH slider.

# ALUMINUM PLATFORM ASSEMBLY

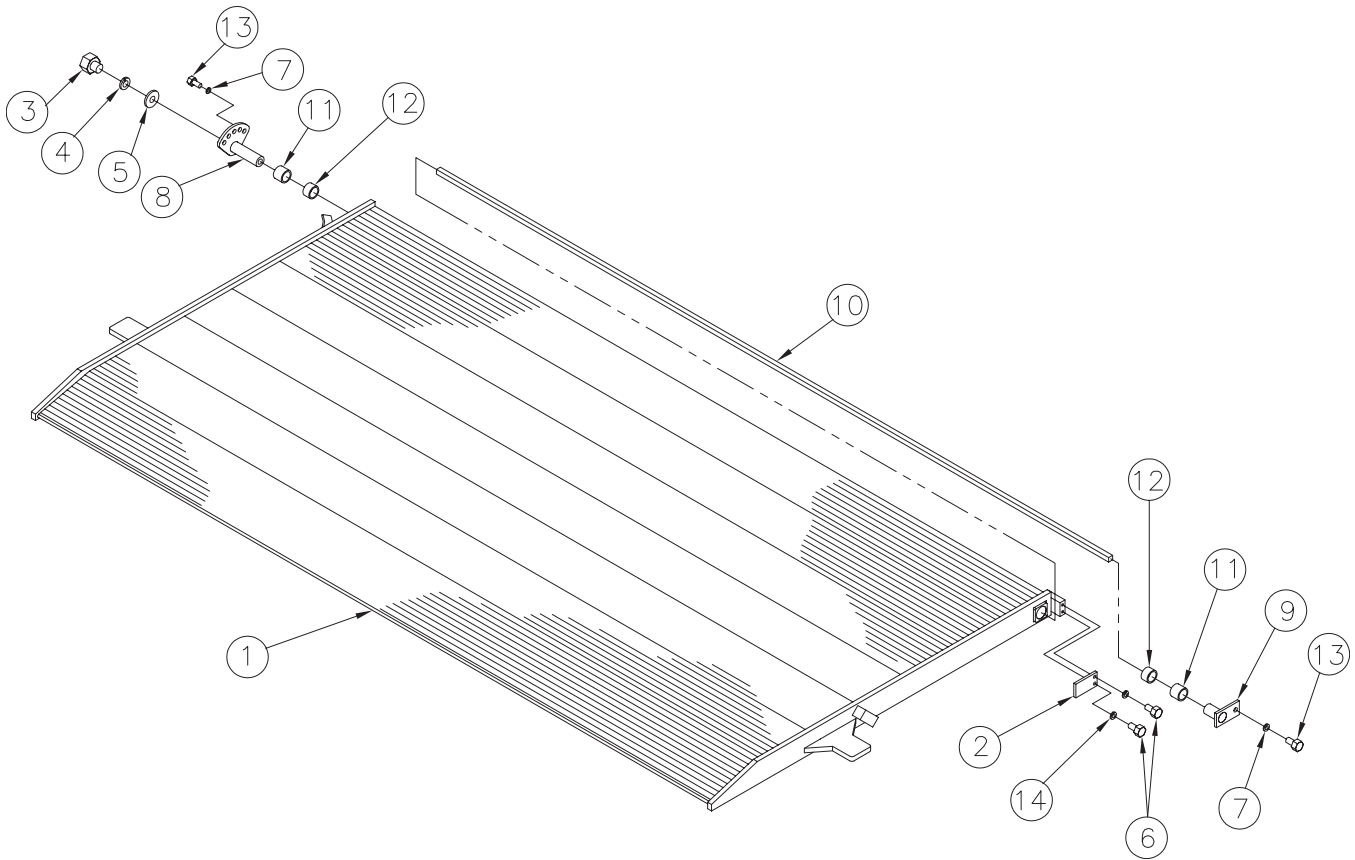

Item	Part Number	Description	Qty.
1	3407-001	7530 Platform	1
1	3407-002	7536 Platform	1
1	3407-003	7542 Platform	1
1	3407-004	7548 Platform	1
1	3407-005	7554 Platform	1
1	3407-006	7560 Platform	1
1	3407-007	7566 Platform (note 1)	1
1	3407-008	8530 Platform	1
1	3407-009	8536 Platform	1
1	3407-010	8542 Platform	1
1	3407-011	8548 Platform	1
1	3407-012	8554 Platform	1
1	3407-013	8560 Platform (note 1)	1
1	3407-014	8566 Platform (note 1)	1
1	3407-017	9042 Platform	1
1	3407-018	9048 Platform	1
1	3407-019	9054 Platform	1
1	3407-020	9060 Platform (note 1)	1
1	3407-021	9066 Platform (note 1)	1

Item	Part Number	Description	Qty.
1	3407-025	9548 Platform	1
1	3407-026	9554 Platform (note 1)	1
1	3407-027	9560 Platform (note 1)	1
1	3407-028	9566 Platform (note 1)	1
1	3407-029	8572 Platform (note 2)	1
1	3407-030	9072 Platform (note 2)	1
1	3407-031	7572 Platform (note 1)	1
1	3407-032	9572 Platform (note 2)	1
2	2329	Stop	1
3	8271713	.62 x .75 Screw	1
4	8121574	.62 Lockwasher	1
5	8130999	.62 Flatwasher	1
6	8109-001	.25 x 1.00 Screw SS	2
7	8120382	.38 Lockwasher	2
8	3108980	Adjusting bracket	1
9	3199	Pin retainer	1
10	5101-001	Torsion bar 85" Platform	1
10	5101-002	Torsion bar 90" Platform	1
10	5101-003	Torsion bar 95" Platform	1
10	5101-004	Torsion bar 75" Platform	1
11	5504-001	Bushing	2
12	5504-005	Bushing	2
13	8180120	.38 x .75 Screw	2
14	8106-002	.25 Lockwasher SS	2

**Notes:**

1. Requires one spring assembly and appropriate RH slider.
2. Requires two spring assemblies and appropriate LH and RH sliders.

# PLATFORM CHAIN ASSEMBLY

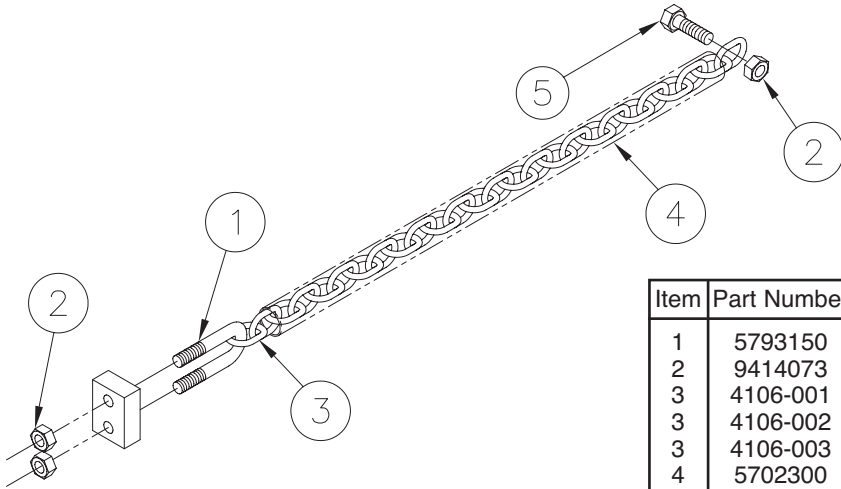

Item	Part Number	Description	Qty.
1	5793150	U-Bolt	2
2	9414073	.44 Locknut	6
3	4106-001	Chain 48,54" deep alum.	2
3	4106-002	Chain 60,66,72" deep alum.	2
3	4106-003	Chain 30,36,42" deep steel or alum.	2
4	5702300	Protective sleeve	2
5	5701910	.44 x 1.50 Bolt	2

# SPRING ASSEMBLY

Item	Part Number	Description	Qty.
1	5793150	U-BOLT	1
2	9414073	Locknut	2
3	5101120	Spring	1

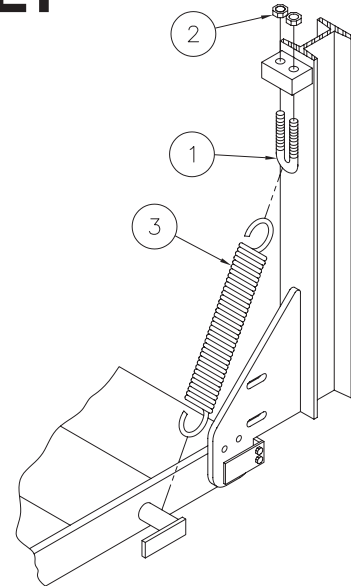

# DAMPER ASSEMBLY

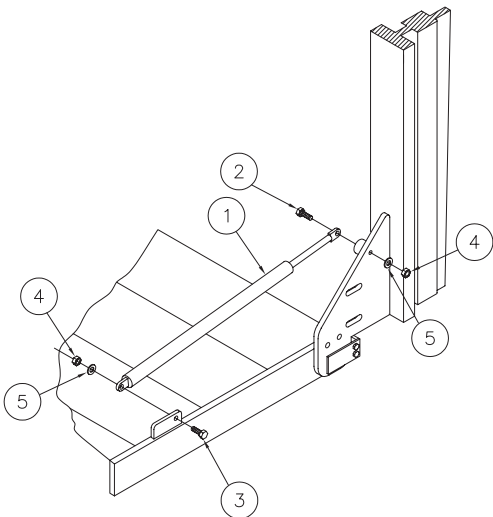

Item	Part Number	Description	Qty.
1	5770	Hyd. Damper	1
2	8104-004	Screw .31-18 x 1.75	1
3	8104-012	Screw .31-18 x 1	1
4	8103-013	Locknut .31-18	2
5	8107-004	Flatwasher .31	2

# HOUSING COVERS

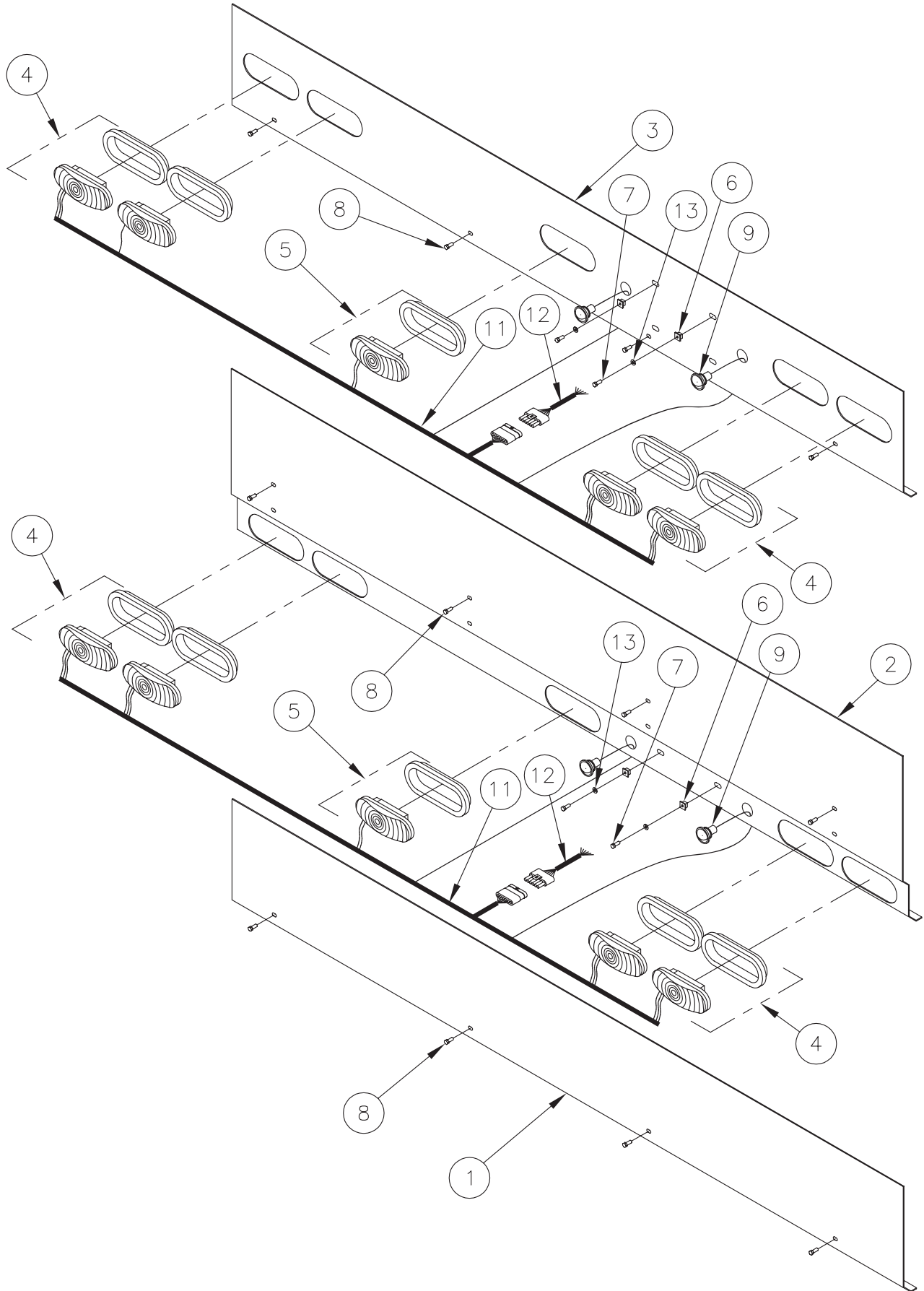

Item	Part Number	Description	Qty.	
			30	30A
1	2714-001	Steel Cover 80	1	1
1	2714-002	Steel Cover 90	1	1
1	2714-003	Steel Cover 95	1	1
1	2714-004	Steel Cover 100	1	1
2	2715-001	Steel Cover 80 W/Lower Lights*	1	1
2	2715-002	Steel Cover 90 W/Lower Lights*	1	1
2	2715-003	Steel Cover 95 W/Lower Lights*	1	1
2	2715-004	Steel Cover 100 W/Lower Lights*	1	1
3	27158-001	Steel Cover 80 W/Upper Lights		1
3	27158-002	Steel Cover 90 W/Upper Lights		1
3	27158-003	Steel Cover 95 W/Upper Lights		1
3	27158-004	Steel Cover 100 W/Upper Lights		1
3	2711411	Alum. Cover 80 W/Upper Lights		1
3	2711412	Alum. Cover 90 W/Upper Lights		1
3	2711413	Alum. Cover 95 W/Upper Lights		1
3	2711414	Alum. Cover 100 W/Upper Lights		1
4	31475	LED Stop/Turn/Taillight	4	4
5	43060	LED Back-up light	1	1
6	5702270	Plastic square nut	2	2
7	5702280	Screw	2	2
8	5793010	.25 x .62 Screw	4	4
9	4300550	License plate light	2	2
10	5792020	Gasket (not shown)	1	1
11	4308	Taillight Wiring Harness	1	1
12	4368	Taillight Wiring Harness	1	1
13	8107-007	Flatwasher	2	2

\*Not for use on Low Bed applications

# CAM CLOSE ASSEMBLY

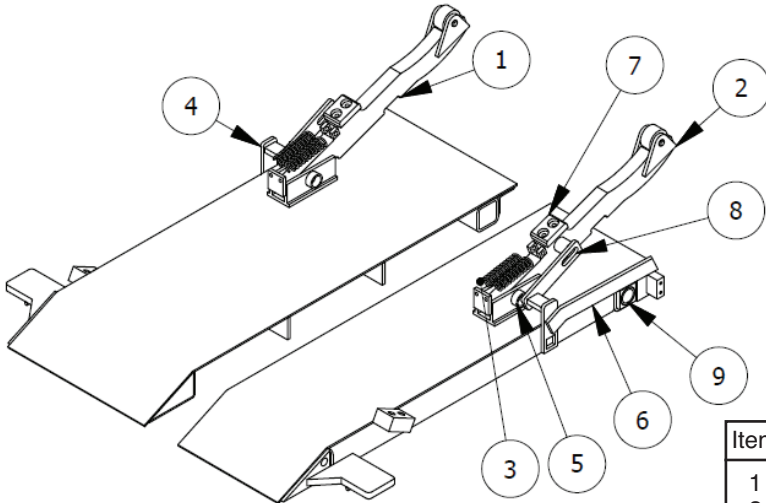

Item	Part Number	Description	Qty.
1	31449-001	Cam Follower Asm	1
2	31449-002	Cam Follower Asm	1
3	5108	Spring	4
4	31460	Linkage Weld LH	1
5	5067	Pin	2
6	31459	Handle Weld RH	1
7	5510	Bearing	2
8	5703	Nylon Pad	2
9	2522-001	Cam Shafts	1
9	2522-002	Cam Shafts	1
9	2522-003	Cam Shafts	1
9	2522-004	Cam Shafts	1

# ELECTRICAL PICTORIAL

## GRAVITY DOWN ELECTRIC CONTROL (TOGGLE OR REMOTE PENDANT)

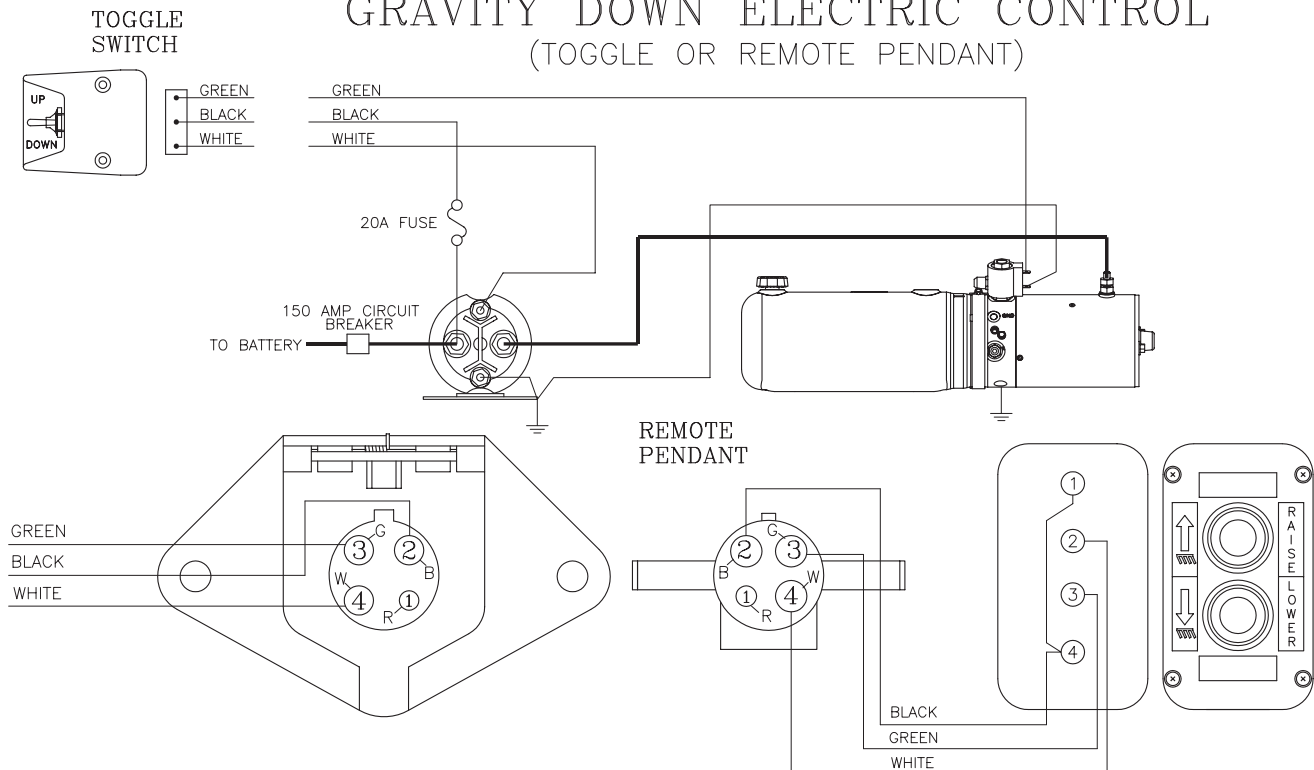

# 2 PC PLATFORM 3 FINGERED HINGE

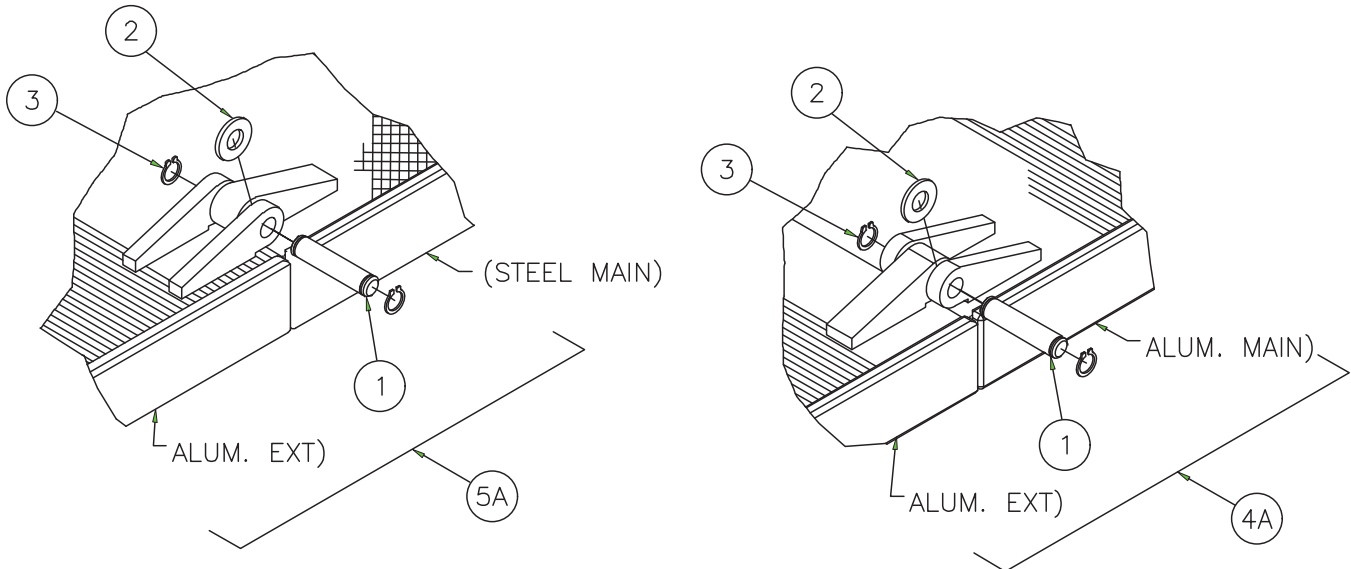

Item	Part Number	Description	Qty.
1	5056	Pin	1
2	8107-011	Washer	1
3	5781017	Snap Rings	2
4A	31277-001	Hinge Asm Alum Main/Alum Ext	1
4B	31277-002	Hinge Asm Alum Main/Alum Ext	1
5A	31279-001	Hinge Asm Steel Main/Alum Ext	1
5B	31279-002	Hinge Asm Steel Main/Alum Ext	1

RIGHT SIDE SHOWN - LEFT SIDE OPPOSITE

## TROUBLESHOOTING GUIDE TVLR-ET

- Test Equipment:**
1. 0-5000 psi pressure gauge
  2. DC voltmeter/ohm meter
  3. DC amp meter
  4. standard mechanics tools

Note: Please refer to the electrical diagrams and hose connection drawings in the liftgate's owners manual when troubleshooting. This guide is only for standard Thieman liftgates. Special liftgates with options other than those in the owner's manual will require special diagrams for troubleshooting. Read and understand this entire guide completely before doing any troubleshooting. Certain listed problems may be related to other problems listed so a comprehensive knowledge is required before proceeding.

### 1. Problem – Pump motor will not run in the raise mode

- Causes –
- a. Tripped circuit breaker
  - b. Blown 20A fuse
  - c. Improper battery cable connection or improper ground connection
  - d. Defective or undercharged battery(ies)
  - e. Defective or improperly wired raise switch
  - f. Defective or improperly wired motor start solenoid
  - g. Defective 2ga. cable/connections from motor start solenoid to pump motor
  - h. Defective pump motor

- Corrections –
- a. Reset the circuit breaker located within 2ft of the liftgate supply battery(ies).
  - b. Replace 20A fuse(s). Each control cord should have a 20A in-line fuse on the black wire, where it connects to the 2ga. battery cable at the motor start solenoid.
  - c. The “at rest” voltage for the batteries without the engine running and under no load should be at least 12.5V, and this voltage should be seen on the heavy 2ga. battery cable, where it connects to the large terminal of the motor start solenoid. The minimum voltage between the motor stud and ground is 10V at maximum conditions, with pump motor, batteries, and cables under max. load. If the voltage is dropping below 10V under max. load, bad connections may be acting like resistors and causing larger voltage drops than expected. Check voltage drops with system under load at different locations between the liftgate and battery source, to locate bad connections along the battery cable. Trace ground cable connections also to locate improper connection(s) along the ground path. Make sure the ground cable is installed going from the pump mounting screws to bare metal on the truck frame. The ground cable from the batteries to the frame must be a heavy 2ga. cable that is connected to bare metal on the frame. Replace any damaged cables and repair any bad connections.
  - d. If proper voltage is not present, load test batteries and replace any defective batteries. The battery(ies) on the vehicle should be that which has a minimum 180 amp reserve capacity.
  - e. Check for voltage on the black wire at the control switch. If no voltage is present the black wire from the motor start solenoid is loose or broken and needs repaired. If voltage is present then check for voltage at the white wire on the switch with the switch in the “RAISE” position. If no voltage is present, replace the switch.
  - f. Check for voltage on the white wire at the motor start switch when the switch is activated. If no voltage exists the white wire is loose or broken between the switch and the motor start solenoid. Check that the purple ground wire on the motor start solenoid is connected properly and there are no bad connections. If there is voltage on the white wire and the coil does not energize or if there is no voltage on the motor side of the solenoid or a large voltage drop present across the large terminals of the motor start solenoid then replace the motor start solenoid.

- g. With the switch in “RAISE” position, check voltage on both ends of the 2ga. cable that runs from the motor start solenoid to the motor. If voltage drops more than .25V across this cable, replace the cable or repair connections on the end of the cables.
  - h. With the switch activated in the “RAISE” position and the motor start solenoid activated, check for voltage at the motor terminal. If 10V is present and the motor is grounded properly, but the motor is not running, replace the motor.
2. Problem – Liftgate will not raise or raises slowly with a load and the pump motor running. The raise speed of the TVL30 on a 56” bed height while empty at 70° F is approximately 13-15 seconds. The raise speed loaded for the same conditions is approximately 29-31 seconds.

- Causes –
- a. Low hydraulic fluid
  - b. Cold weather
  - c. Overload condition
  - d. Low voltage and/or bad ground
  - e. Improperly adjusted or defective main relief valve
  - f. Lift cylinder is bypassing, liftgate is drifting down
  - g. Broken hydraulic line
  - h. Clogged or disconnected suction line
  - i. Defective or worn out pump

- Corrections -
- a. Make sure the reservoir has the proper amount of fluid. The hydraulic fluid should be within ½ ” of the top of the reservoir with the liftgate in the lowered position. Fill reservoir with Dexron III or other acceptable fluid (see Hydraulic Fluid Chart in “Maintenance Guide” section of this manual). Low fluid levels can introduce air, which will compress and slow the liftgate speed, especially when loaded.
  - b. Refer to Hydraulic Fluid Chart in “Maintenance Guide” section of this manual, for alternative oils to use for cold weather conditions.
  - c. The power unit on the TVLR30 is equipped with a lifting relief valve to prevent overloading of the liftgate (see relief setting in “Maintenance Guide” section of this manual). Do NOT overload the liftgate.
  - d. If the voltage reaching the motor drops below 10V under max. load conditions, this low voltage can cause the liftgate to slow. If voltages get low enough or ground is inadequate, the liftgate may not raise at all (see Problem 1) and will not be able to develop the rated relief pressure.
  - e. See section “c” above for relief valve setting. Remove all loads from the liftgate’s platform. Plumb a pressure gauge into the high pressure circuit of the liftgate. Engage the “RAISE” switch until the liftgate is fully raised. Keep the “RAISE” switch engaged until the pump bypasses through the relief valve and note the pressure on the gauge at this time. If the rated relief pressure is not present during relief, adjust the high pressure relief valve setting as necessary. If the relief pressure is not attainable the relief valve must be cleaned and/or replaced or the pump is defective (see part “h” below).
  - f. If the liftgate will not raise with a load on the platform but empty is raising slowly or partially, the cylinder may be bypassing. To check for a bypassing cylinder do the following. Lower the gate to the ground to relieve all pressure from the cylinder. Disconnect the cylinder from the pusher. Press the “RAISE” switch until the cylinder is fully extended and continue holding “RAISE” switch for 15 to 20 seconds and watch for a steady stream of fluid coming out of the breather port (in lock-ring slot of cylinder on underside of barrel on rod end). Replace or rebuild any cylinders with fluid coming out of the breather port, as this indicates fluid is bypassing the piston seals on the cylinder. Reconnect rebuilt or replaced cylinder and hoses as before.
  - g. Broken or punctured hydraulic lines and fittings must be replaced with care to avoid injury from high pressure oil streams.
  - h. With the liftgate at the ground, disconnect the power unit and remove the reservoir. Check to see if the suction tube is clogged or has fallen out of the pump base. Clean the screen or reattach the suction tube as required.

- i. If all else fails replace the power unit, it may be defective. If liftgate older, the pump may be worn out and unable to pump fluid at pressure with the correct flow rate.

3. Problem – Liftgate will not raise completely for maximum travel.

- Causes -
- a. Low hydraulic fluid
  - b. Improperly adjusted lift chains
  - c. Rails not lubricated their entire length

- Corrections -
- a. Make sure the reservoir has the proper amount of fluid. The hydraulic fluid should be within ½” of the top of the reservoir with the liftgate in the lowered position. Fill reservoir with Dexron III or other acceptable fluid (see Hydraulic Fluid Chart in “Maintenance Guide” section of this manual). Liftgate travel may be limited if the reservoir is not properly filled.
  - b. If either side or both sides of the platform fail to reach truck bed level by a small amount, refer to the platform level adjustments under the Monthly Inspection and Maintenance section of the “Maintenance Guide” in this manual to make necessary adjustments. Curb side and street sides of the liftgate can be adjusted independently to obtain a level platform. If the platform raises level to bed with no load, but is about 1 inch short with a load, this is likely due to the main lift chains stretching under load, which is normal. Adjust the chains so the platform can raise level to bed with the heaviest load to be lifted. The Thieman factory sets the platform to travel approximately 1 inch above truck floor level, to compensate for this chain stretch under load.
  - c. Make sure the liftgate frame rails are lubricated according to the “Maintenance Guide”. Incomplete lubrication over the length of each frame rail can lead to increased friction in the frame rails and these frictional loads reduce the amount of load the liftgate can raise before exceeding the relief pressure of the hydraulic system.

4. Problem – Liftgate will not lower

- Causes -
- a. Defective lowering solenoid coil or valve
  - b. Clogged or defective hydraulic lines, fittings or flow controls

- Corrections -
- a. With the “LOWER” switch engaged check for voltage on the green wire at the switch. If no voltage is present replace the switch. If voltage is present, with the “LOWER” switch engaged, check for voltage at the green wire on the lower solenoid valve coil terminal. If no voltage is present, the green wire from the “LOWER” switch is loose or broken and needs replaced. Check for proper ground at the purple wire on the lowering solenoid coil. Repair or replace ground as required. If there is voltage (minimum of 9.5 volts) and proper ground at the lowering coil, and the valve is not opening to allow the gate to lower, either the lower coil is bad or the entire lower coil/valve assembly is bad. To check to see if the coil is defective, remove the green and purple wires from the spade terminals on the lower coil and check the resistance between these spade terminals (3.6 - 4.4 Ohm acceptable). If proper resistance does not exist, replace the defective coil, otherwise replace the defective lower coil/valve assembly.
  - b. Remove any obstruction in the hoses, fittings, restrictor elbows or flow controls. Replace any kinked or obstructed hose, fitting or flow control, which does not allow fluid to flow through properly.

5. Problem – Foamy oil flowing from reservoir breather

Causes - a. Air is present in the system

Corrections a. This can occur if air enters the system when the fluid level is low, see problem 2, part a, or if the suction tube is disconnected, see problem 2, part h. Also, air may enter through fittings, which are not tightened properly, so check for any leaks around fittings or hoses. Once the source of the air is determined, the cylinder must be bled of all air. To bleed all air from system, lower the gate to the ground. Once the liftgate is at ground, have one person hold the DOWN switch while another person manually pushes the cylinder into its fully retracted position. It may be necessary to loosen the hose to cylinder connection to ease this process, but fluid will leak at fitting as cylinder is retracted. Once the cylinder is fully retracted, loosen the hose to cylinder connection if not done previously. Then bump the UP switch intermittently until all air is forced out of the hydraulic hose. Tighten fitting immediately to seal out air, once only hydraulic fluid is present.

6. Problem - Liftgate chatters when raising or lowering

Causes - a. Inadequate lubrication between sliders and rails  
b. Rail wear surfaces are dirty & contaminated  
c. Wear pads are worn down or embedded with contaminants  
d. Wear pad mounting screws are loose  
e. Slider rollers are not turning freely  
f. Platform chains are not in equal tension

Corrections - a. The rails should be lubricated on a regular basis. See the Owner's Manual for the type and frequency of lubrication and the locations for lubricating. Lubricate each frame rail on 4 surfaces where slider wear pads or rollers make contact over the entire length of each rail. **DO NOT USE GREASE!**  
b. If lubrication of the rails does not eliminate the chattering it may be necessary to completely clean the rails, slider wear pads, and rollers. The sliders should be removed from the rails to thoroughly clean the rails, slider wear pads and rollers. All contaminants must be removed from the rail including grease, rust, paint overspray, etc., such that only bare metal remains. Lubricate the pads and rails before reassembly. See step c.  
c. If the wear pads are worn down to the mounting screw heads or if they are embedded with contaminants (rust, road debris, paint overspray, etc.), it will be necessary to replace them at this time.  
d. The wear pads at the top of the sliders are secured using screws and center detent locknuts. Retighten locknuts or replace hardware if locknuts are no longer tight (locking) on screws. The lower wear pads below the rollers, use self-tapping screws. Apply a thread locker loctite to the threads of the screws and tighten.  
e. Make sure all slider rollers can be rotated by hand fairly easily. If a liftgate is older, the rollers may not spin like they are brand new, but they should turn fairly easily by hand. If a roller will not turn by hand, look for flat spots on the rollers or skid marks in the rails, which would further indicate the rollers are not turning freely. Replace any roller that does not turn freely  
f. Adjust the platform support chains so they are in equal tension.

If you have any questions or problems that are not covered in this guide please call Thieman's Engineering Department at 1-800-524-5210.





