

TVLR *SERIES*

Railgates By THIEMAN

TVLR 20, 20A OWNER'S MANUAL/PARTS LIST

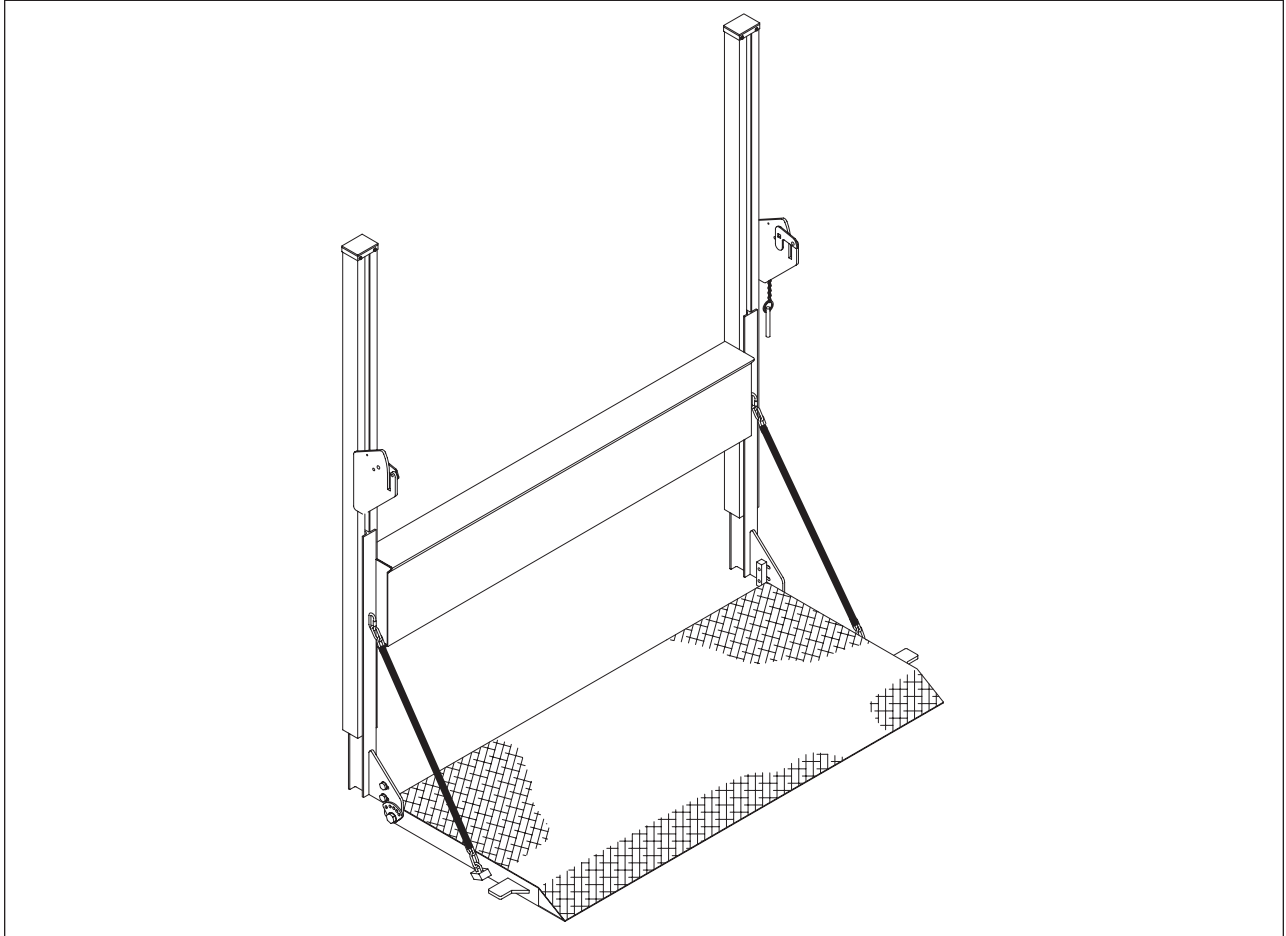

IMPORTANT! KEEP IN VEHICLE!

PLEASE READ AND UNDERSTAND THE CONTENTS OF THIS
MANUAL BEFORE OPERATING THE EQUIPMENT.

THIEMAN
TAILGATES, INC.

600 East Wayne Street
Celina, Ohio 45822

Phone: 419-586-7727 Fax: 419-586-9724
www.thiemantailgates.com

NTEA
THE ASSOCIATION FOR THE WORK TRUCK INDUSTRY
MEMBER

TABLE OF CONTENTS

	PAGE
PARTS ORDERING PROCEDURE	2
SAFETY INFORMATION & WARNINGS	3-7
OPERATING INSTRUCTIONS	8
MAINTENANCE GUIDE & MONTHLY INSPECTION AND MAINTENANCE	9-12
SEMI-ANNUAL INSPECTION & MAINTENANCE	12
DECAL MAINTENANCE - INSPECTION AND LOCATION OF DECALS	13
MAIN FRAME ASSEMBLY	14,15
LIFTING CHAIN ASSEMBLY	16
SLIDER ASSEMBLY	17
STEEL PLATFORM ASSEMBLY	18
ALUMINUM PLATFORM ASSEMBLY	19
PLATFORM CHAIN, SPRING & DAMPER ASSEMBLES	20
HOUSING COVERS	21-22
CAM CLOSE/ ELECTRICAL PICTORIAL	23
2 PC PLATFORM 3 FINGERED HINGE	24
TROUBLESHOOTING GUIDE	25-28

FOR YOUR RECORDS

Model No. _____ Date Purchased _____

Serial No. _____

NOTE: When Ordering Parts Be Sure To Include This Information!

Your Thieman Tailgate is constructed of top quality material and is warranted to be free from defects in material and workmanship under normal use. With routine maintenance and proper operation this liftgate will provide long lasting service and dependability.

PARTS ORDERING PROCEDURE

When ordering parts, please include all the information asked below. If this information is not available, a photo of the required part MAY help Thieman identify and deliver the needed part to you.

THE FOLLOWING INFORMATION MUST BE INCLUDED:

1. Serial Number - Thieman TVLR liftgate serial numbers can be found on the tag located on the inner or outer side of the curb side frame rail.
2. Model number and capacity
3. Platform size and material - steel or aluminum
4. Part number
5. Description
6. Quantity required

SAFETY INFORMATION



This is the safety alert symbol. This manual uses this symbol combined with the Signal Words below, which together, alert you of potential personal injury hazards. **Obey all safety messages throughout this manual, including those that follow the Signal Words below, to avoid personal injury or death.** Each Signal Word is explained below.

SIGNAL WORDS used in this manual



DANGER

DANGER – Indicates a hazardous situation which, if not avoided, will result in death or serious injury.

Related information will follow



WARNING

WARNING – Indicates a hazardous situation which, if not avoided, could result in death or serious injury.

Related information will follow



CAUTION

CAUTION – Indicates a hazardous situation which, if not avoided, could result in minor or moderate injury.

Related information will follow

WARNING

IMPROPER OPERATION OF THIS LIFTGATE MAY RESULT IN SERIOUS PERSONAL INJURY AND/OR DEATH. DO NOT operate this liftgate unless you have been properly instructed and have read and understood the Owner's Manual and all of its warnings, operating instructions and all decals.

The following list of warnings is to be read and understood before operating the TVLR series liftgate. The numbered list begins below and continues on the following pages.

WARNINGS!

1. DO NOT operate this Thieman liftgate without the Owner's Manual for this model present on the vehicle and without all decals present and legible, as guides for proper liftgate operation and maintenance (see the "Decal Maintenance - Inspection and Location of Decals" section of this manual). For replacement Owner's Manuals, decals, etc. call Thieman at 419-586-7727. For the latest manuals and warnings for each liftgate, visit our website at www.thiemantailgates.com. Note: manuals and warnings update regularly.
2. The vehicle must be securely and properly braked on level ground before using the liftgate.
3. All protective covers and guards must be in place before operating the liftgate.
4. Before using liftgate, check for signs of improper maintenance or damage (unusual noises, vibrations, fails to operate freely, missing hardware, cracked welds...etc. See the sections in this manual with "Maintenance" in the title – refer to "Table of Contents" on Page 2). DO NOT use the lift if these are evident. Only an authorized Thieman distributor is qualified to do repairs on the liftgate. DO NOT attempt to do your own repairs or modify this liftgate. Altering this product will void all warranties and may damage the liftgate or even cause serious injury. If any repairs, adjustments, or maintenance not covered in this manual are required, contact your nearest Thieman distributor or call Thieman at 419-586-7727.
5. THIS IS NOT A PERSONNEL LIFT. Because of the pinch point between the platform and the truck, fall hazards, unstable loads, etc., riding the lift may cause severe personal injury or death. ALWAYS stay clear of the liftgate when in operation. Do NOT ride the liftgate.
6. Make certain the areas, in which the platform will open or close, are clear before opening or closing the platform.
7. Use this liftgate ONLY for its intended purpose of loading/unloading cargo between truck bed and ground. It is NOT to be used for anything other than this. The ground is defined as the surface the truck is parked on.

(Warnings continued on following pages)

8. DO NOT OVERLOAD THE LIFTGATE. Each liftgate has a specific maximum capacity for lifting and lowering. The standard maximum rated capacity of the TVLR series liftgates differs with each model as follows:

TVLR20-2000 lbs. Maximum Load

WARNING note: Special options can lower the maximum rated capacities below those shown above. Be certain you know what the maximum rated capacity is for your particular liftgate.

9. NEVER off-center the load on the platform, from side to side or away from truck as this may overload the liftgate. The center of weight of the load should NEVER be placed beyond the center of the platform load surface, away from truck. Loads should be placed close to platform edge nearest truck. See figure 1.
10. NEVER allow any part of the load to extend beyond the edges of the platform's flat load surface. Overhanging objects increase the risks of tipping loads due to unstable loading or snagging these objects on surroundings and THESE OBJECTS COULD ALSO STRIKE OR CRUSH OPERATORS OR BYSTANDERS.
11. NEVER step on or place loads on, the ramp portion of any liftgate platform (includes all ramp styles), unless the platform is lowered completely to the ground and the entire platform and ramp are supported by the ground.
12. NEVER lift or lower unstable loads.
13. NEVER operate liftgate if platform load surface is slippery.
14. Make certain the areas above and below the liftgate platform and other moving liftgate parts, are clear before, and at all times during, operation of the liftgate. Do NOT allow anyone to stand around the platform where a falling load could land on them.
15. Load and unload the platform from the rear and not from the side of the platform. Never remove the platform support chains to load or unload the platform.
16. Never operate lift trucks on or over any part of the platform.
17. Follow all sections in this manual with "Maintenance" in the title – refer to "Table of Contents" on Page 2.
18. NEVER move vehicle unless platform is properly stowed and power is off. An open liftgate on a moving vehicle poses a serious traffic hazard.

(Warnings continued on following pages)

19. ALWAYS stow liftgate in transit position when not in use. Liftgates left in their open positions, may create hazards for people and vehicles passing nearby.
20. Take care to retain cargo during transit. Liftgates are not designed to retain objects on the truck. Improperly retained objects may fall from the vehicle and pose serious traffic hazards and larger objects could shift and damage the liftgate or truck
21. Any time the vehicle is washed, this liftgate MUST be inspected to MAKE SURE all parts are properly lubricated and have the appropriate protectants. Failure to replace lubricants and protectants after washing the vehicle, may lead to improper operation of the liftgate, accelerated corrosion, and possible component failure.

WARNING

An improperly positioned load can overload the liftgate and result in sudden liftgate failure and/or increased risks to personnel of being hit or crushed by loads. **IMPROPERLY POSITIONED LOADS MAY RESULT IN SERIOUS PERSONAL INJURY AND/OR DEATH.** Always position loads properly on the liftgate platform. Follow information below on how to position loads properly.

POSITION LOADS PROPERLY ON PLATFORM

NEVER off-center the load on the platform, from side to side or away from truck as this may overload the liftgate. The center of weight of the load should NEVER be placed beyond the center of the platform load surface, away from truck. Loads should be placed close to the platform edge nearest truck. If a load is not uniformly distributed, then the heaviest portion should be closest to the edge of the platform nearest the truck. NEVER allow any part of the load to extend beyond the edges of the platform's flat load surface. NEVER allow any part of the load to extend over or on, the tapered ramp portion of the platform unless the platform is lowered completely to the ground and the ramp is supported by the ground.

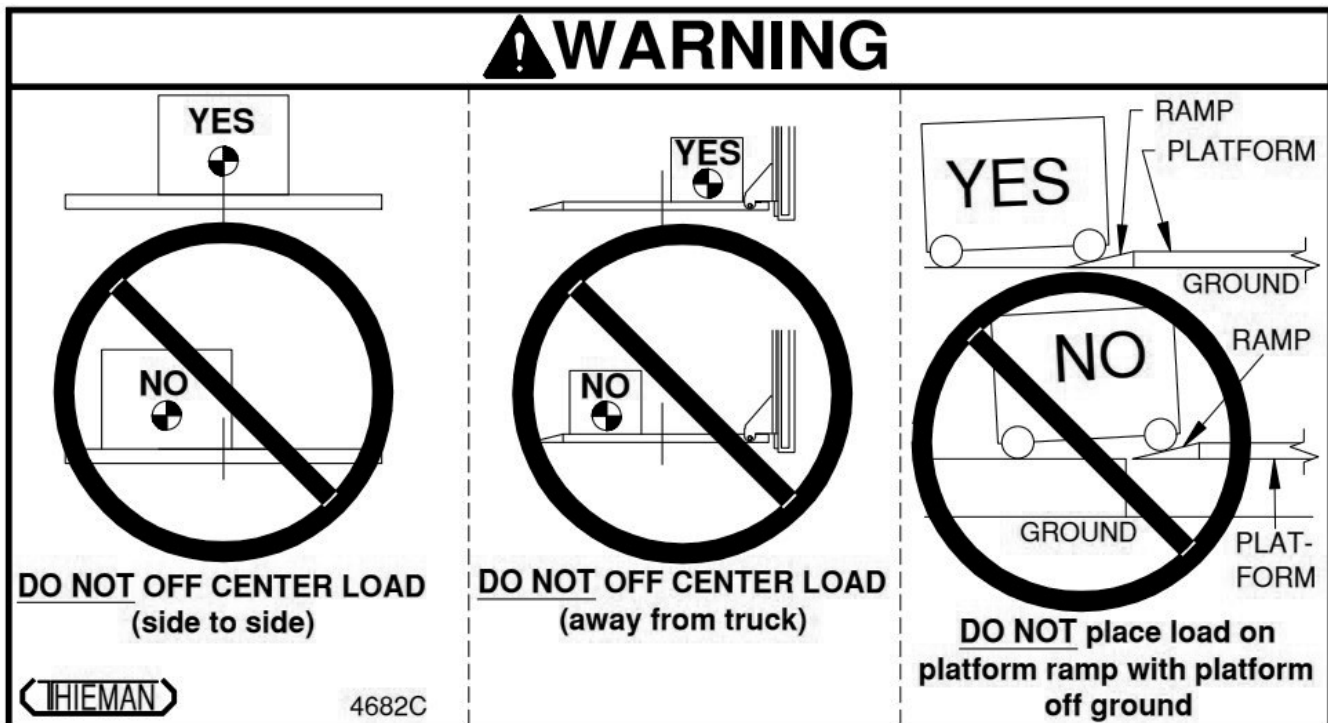

Fig. 1

DO NOT OVERHEAT THE HYDRAULIC PUMP

Exceeding the duty cycle of the hydraulic pump, can overheat many components, including the gear pump, the hydraulic motor, the motor start solenoid, valve coils, etc., and significantly shorten the expected life of these components. In extreme cases, immediate damage to the pump or related components may occur. Refer to the Thermal data below.

THERMAL DATA: To avoid overheating the motor do not operate this unit for more than 5 cycles/ 10 minutes with the maximum load. The motor then must be allowed to completely cool down to ambient temperature before cycling the lift again. This unit also has a 10% duty cycle, which means the liftgate can be cycled no more than 2 cycles/10 minutes constantly with the maximum load.

WARNING

IMPROPER OPERATION OF THIS LIFTGATE MAY RESULT IN SERIOUS PERSONAL INJURY AND/OR DEATH. DO NOT operate this liftgate unless you have been properly instructed and have read and understood the Owner's Manual and all of its warnings, operating instructions and all decals.

OPERATING INSTRUCTIONS

Be sure to operate liftgate at a safe distance and never improperly load platform as this may cause personal injury or damage to the liftgate.

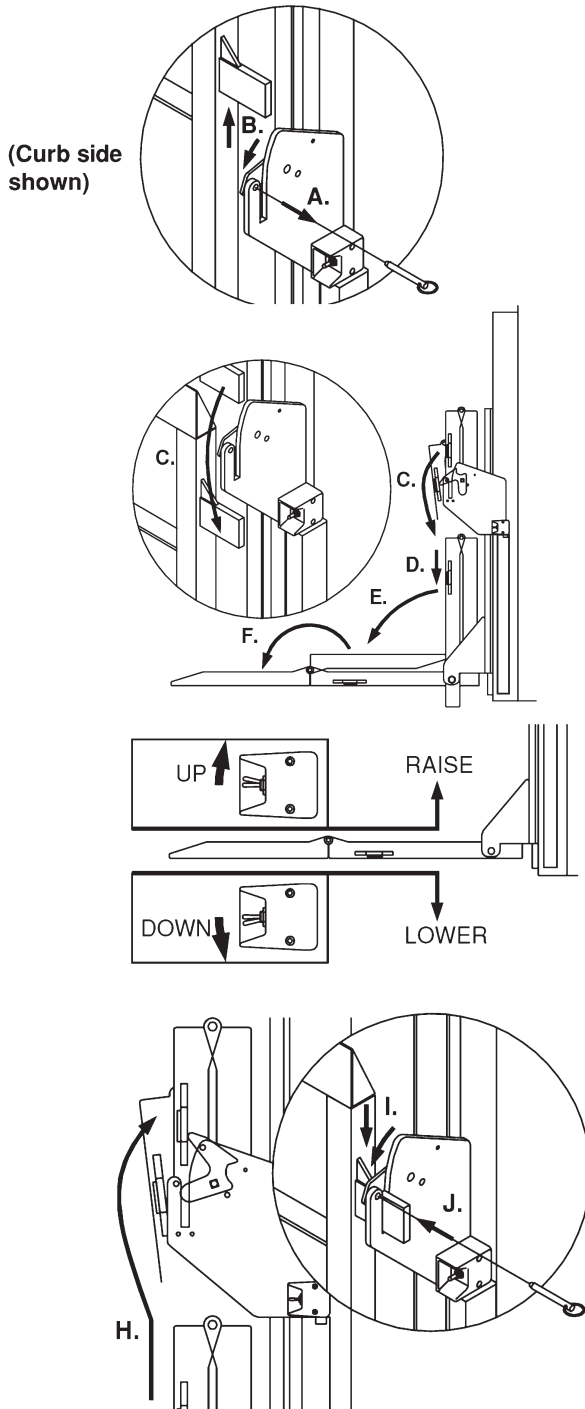

1. UNLOCK

- A. Remove curb side AND street side latch pins from resting plates.
- B. Raise liftgate until locking cams rotate back down

2. UNFOLD

- C. Lower liftgate, so guide plates ride over cams, and are below resting plates
- D. Lower liftgate to a comfortable height to unfold the platform.
- E. Manually unfold platform slowly to horizontal position. Don't let it fall.
- F. Unfold secondary platform sections if so equipped. Don't let them fall.

3. RAISE OR LOWER

- G. Use toggle switch or other supplied control to raise or lower liftgate.

4. STORE FOR TRANSIT

- H. Reverse Step 2 above. Fold platform to vertical position and raise folded liftgate until locking cams on resting plates are rotated up and stowage slot in resting plates are exposed.
- I. Lower liftgate until locking cams rotate back down.
- J. Reinsert curb side AND street side latch pins into holes of resting plates and locking cams.

WARNING

IMPROPER MAINTENANCE OF THIS LIFTGATE MAY RESULT IN SERIOUS PERSONAL INJURY AND/OR DEATH. Never use a liftgate, that has not been properly maintained. Follow all maintenance outlined in this manual, beginning with “Maintenance Guide” thru and including “Decal Maintenance - Inspection and Location of Decals”.

MAINTENANCE GUIDE

The following inspection and maintenance operations should be performed at the recommended intervals or anytime the liftgate shows signs of abuse and improper or abnormal operation.

MONTHLY INSPECTION AND MAINTENANCE

Operate the liftgate throughout its entire operational cycle and check the following:

1. Check that there are no unusual noises or vibrations.
2. Check that the platform is level front to back and side to side when raised to bed height. If front to back adjustments are necessary, this can be done by adjusting nuts (A) on U-bolt (B) on platform block (C). See figure 2. If side to side adjustments are necessary, this can be done by adjusting nuts (D), nylon insert locknuts (E), and lockwashers (F) on tension rods (G) on anchor bracket (H). See figure 2.

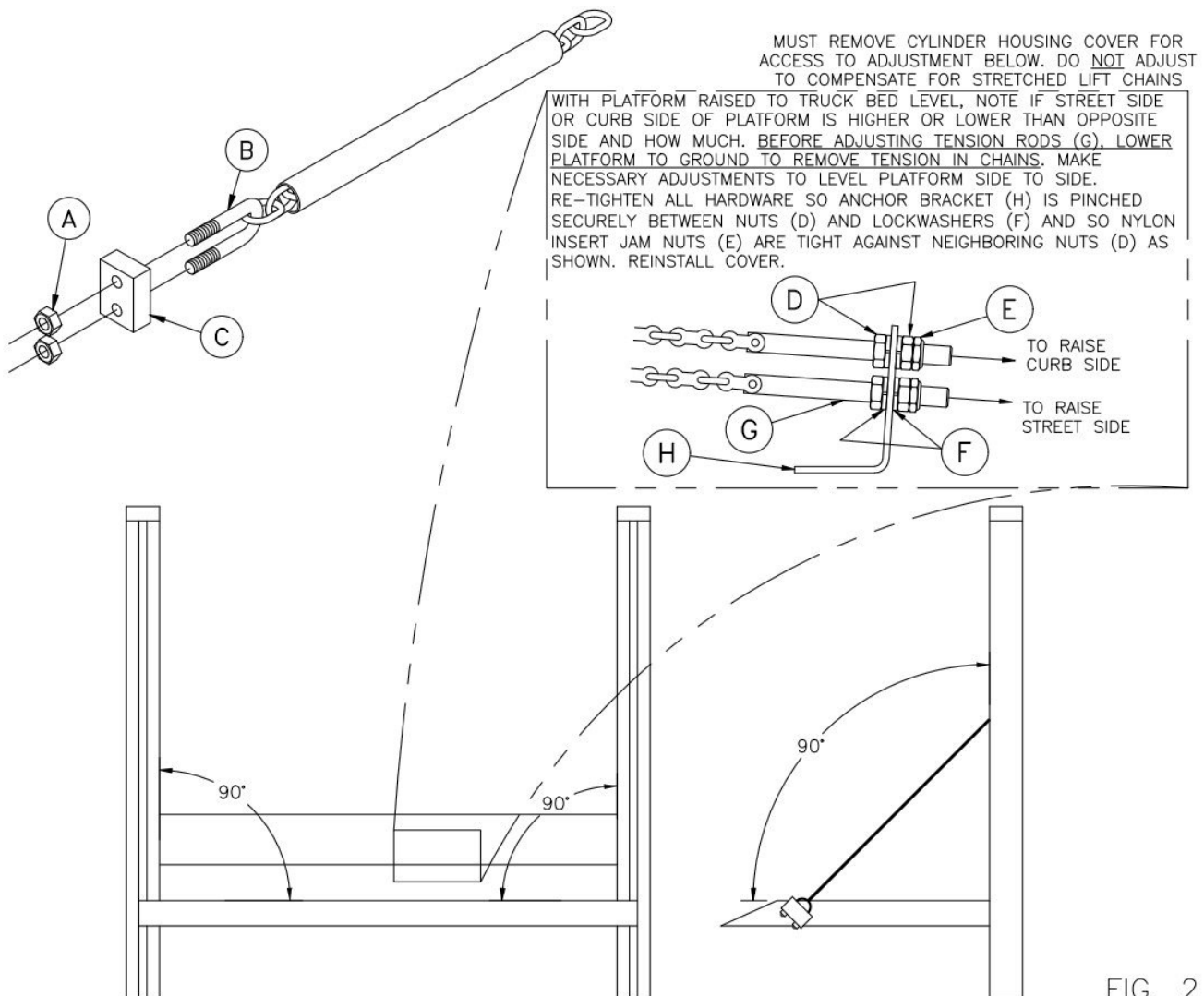

FIG. 2

3. Check for apparent damage to the liftgate such as bent or distorted members, any cracked welds, which may have resulted from overloading or abuse.
4. Check for any excessive wear in the following pivot areas (Note: For bushed pivots, if the gap between pin and bushing exceeds 1/32 of an inch, the bushing should be replaced. For pivots without bushings, replace worn components if gap between pin and pivot exceeds 1/32 of an inch. Refer to parts breakdowns in this manual):
 - A. Cylinder pin.
 - B. Adjustment bracket, pin retainer and bushings joining sliders to platform.
 - C. Slider roller assemblies (roller and bearing) and pins.
 - D. Nylon wear pads on slider.
 - E. Pusher wear pad
 - F. Chain roller assemblies, bushings and pins.
 - G. Platform support chains and chain anchor points.
 - H. Lift chains-replace if stretched or non-flexible.
 - I. Platform hinge pins, and bushings (two-piece platform only).
5. Check that all platform pivot pins are in place and retained by their proper retainers. The street side platform pivot pin (Adjusting Bracket) is bolted to the slider pivot with a 3/8 bolt. There is a formed retainer welded to the street side of the platform, which wraps around the slotted plate of the Adjusting Bracket in the stored position and holds the street side platform pivot pin in the platform pivot. The curb side platform pivot pin (Pin Retainer) is bolted to the slider pivot with a 3/8 bolt. There is a Stop, which is bolted to the curb side of the platform with two 1/4 inch screws which holds curb side platform pivot pin in the platform pivot.
6. Check that all protective covers and guards are properly in place and secured.
7. Check painted finish, if in poor condition, repaint. Mask any rail opening to avoid overspray. Any rusted parts should be replaced.
8. Check condition of non-painted parts, replace if corrosion exists.
9. Check for oil leaks in these areas:
 - A. Lift cylinder
 - B. Hydraulic hose - replace if it shows signs of wear or cracking.
 - C. Hydraulic fittings - tighten or replace as may be required to stop leakage.
10. Check the oil level in the hydraulic reservoir located in the cylinder housing. With the platform open and at ground level, the oil should be within 1/2 inch from the top of the reservoir. See chart below.

HYDRAULIC FLUID CHART	
Temperature Range	Acceptable Fluids
-75° F to 165° F	Exxon Univis J-26
-20° F to 130° F	Dexron III Exxon Superflo ATF Shell Spirax S3 ATF MD3
-50° F to 80° F	Shell Aero Fluid 4 Mobil Aero HFA Exxon Univis J-13 MIL H-5606

11. Check that all wiring and battery cable connections are tight and free of corrosion.

12. Lubrication of the TVLR series gate should be as follows for all user conditions.

Area of Tailgate	Type of Lubrication	*Frequency
Vertical Rails	SAE 10 to SAE 20 oil	50 cycles
Lift Chain	SAE 10 to SAE 20 oil	100 cycles
Chain Anchor Links	SAE 10 to SAE 20 oil	100 cycles
Locking Cams	SAE 10 to SAE 20 oil	100 cycles

ATTENTION

WEEKLY LUBRICATION REQUIRED

LUBRICATION OF RAILS IS REQUIRED EVERY WEEK OR EVERY 50 CYCLES, WHICHEVER COMES FIRST.

VERTICAL RAILS (2)

OIL HOLES (4)

I-BEAM SLIDERS (2)

VERTICAL RAIL CROSS-SECTION
(4 SURFACES TO OIL PER RAIL)

1 2

3 4

LUBRICATION INSTRUCTIONS

1. Lower gate to the ground.
2. Apply SAE 10W or 20W oil at the top of each vertical rail on the 4 surfaces shown using oil holes if necessary.
3. 4 surfaces must be bare metal, free of all contamination such as rust, paint overspray, grease, etc.
4. Let oil run down rails to sliders.
5. Cycle liftgate a few times from fully lowered to fully raised. Oil must be evenly spread on all 4 surfaces shown from top to bottom of each rail.

4662B

*NOTE: TVLR gates which see less than 50 cycles per week must be lubricated in the areas listed above no less than once a week. Once lubricated, run the gate up and down through one complete cycle to spread lubricant more evenly.

13. Check the pump relief pressure and also the motor amperage at this pressure. These values should be as follows:

Model	Max Amp Draw	Relief Pressure (psi)
TVLR20	165	3000

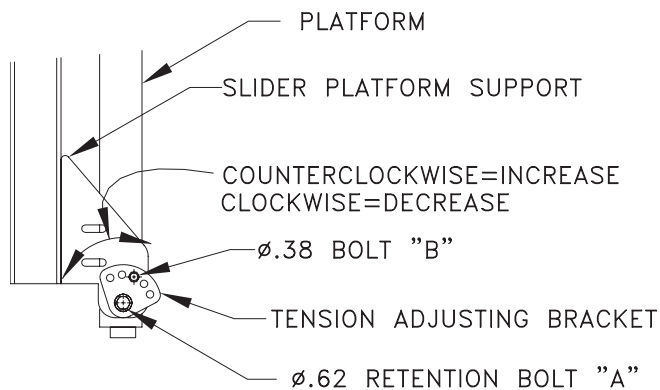
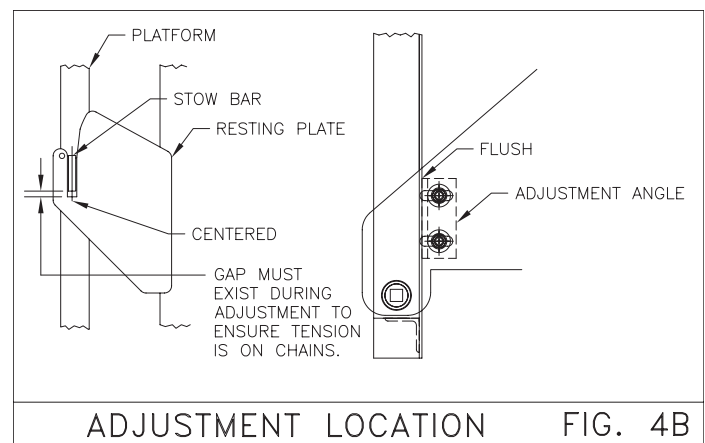
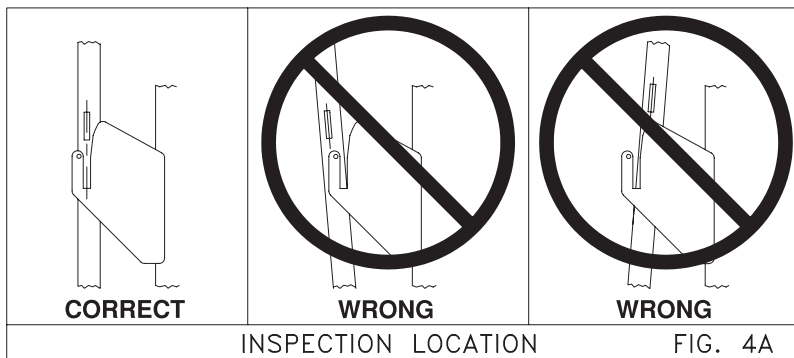

FIG. 3

14. Torsion bar adjustment (See figure 3).
 - A. Place platform in stowed (vertical) position.
 - B. Remove 5/8" diameter bolt (A) from center of tension adjusting bracket.
 - C. Place 1/2" square breaker bar in the square hole of the adjusting bracket pin.
 - D. Turn breaker bar counterclockwise to relieve tension on 3/8" diameter bolt (B) and remove it from the bracket.
 - E. To increase tension, rotate bracket counterclockwise until desired tension is reached. Line up hole in bracket to hole in slider platform support and replace bolt (B).

15. Set adjustment angles on either side of liftgate to hold platform vertical such that the stow bars on platform are aligned with the resting plate slots. Inspect alignment with stow bars raised completely out of resting plate slots (See figure 4A). If they are out of alignment, put the platform in the stored position. Raise platform slightly, so that stow bars are not sitting on the bottom of the resting plate slot, so there is tension in chains (See figure 4B). Then, unloosen screws on the adjustment angles and move angles so they are tight against the vertical platform. Once angles are adjusted, tighten screws. Be sure to do this for both sides. Repeat inspection of stow bar alignment and readjust if necessary. Failure to keep stow bars aligned with resting plate slots can result in excessive wear of stow bars and resting plates.



Semi-Annual Inspection

1. Perform the procedures outlined in the “Monthly Inspection and Maintenance.”
2. Inspect pump motor by:
 - A. Disconnecting battery cable
 - B. Remove motor end cover
 - C. Examine the armature brushes for wear. (Brushes should be replaced if they are less than 1/8” long).
 - D. Clean all residue out from inside of the motor housing.
 - E. Apply several drops of light weight machine oil to the armature shaft bearing in the motor end cover and reassemble the motor end cover.
3. If the hydraulic oil in the reservoir is dirty:
 - A. Unfold platform and lower platform to the ground so the cylinder is fully retracted.
 - B. Drain the oil from the hydraulic system and flush the entire system.
 - C. Remove the reservoir from the pump and clean the suction line filter. Also clean out any contaminants from the reservoir. Remount the reservoir when completed.
 - D. Replace the oil as outlined in Section 10 under Monthly Maintenance and Inspection.

DECAL MAINTENANCE - INSPECTION AND LOCATION OF DECALS

! WARNING

IMPROPER OPERATION OF THIS LIFTGATE MAY RESULT IN SERIOUS PERSONAL INJURY AND/OR DEATH. Liftgate decals provide important information, which is vital for proper and safe operation of the liftgate. Replace any decals which are missing or which are not fully legible.

DO NOT operate liftgate unless all decals are legible and are properly located.

LIST OF DECALS AND LOCATIONS

Item	Part Name	Part Number
1	Warning Decal-center load	4682
2	Fast Idle Decal	4650150
3	Danger Decal-no riding	4609
4*	*Operating Decal - standard	4650780
5	Capacity Decal 2000#	4650100
6	Warning Decal-pinch point	4650790
7	Caution Decal-cover	4650760
8	Warning Decal-working area	4650770
9	Reflector(3)	5705
10	Thieman Nameplate	4650801
11	Toggle Switch Decal(1)	4650820
12	Wiring Decal	4617
13	Warning Decal-high pressure	4620
14	Lubrication Decal	4662
15	Lube Location Decal(4)	4663
16	Warning Decal - general warning	4681
	*Operating Decal (Cam Close/Open)	4674
	*Operating Decal (Cam Close)	4655

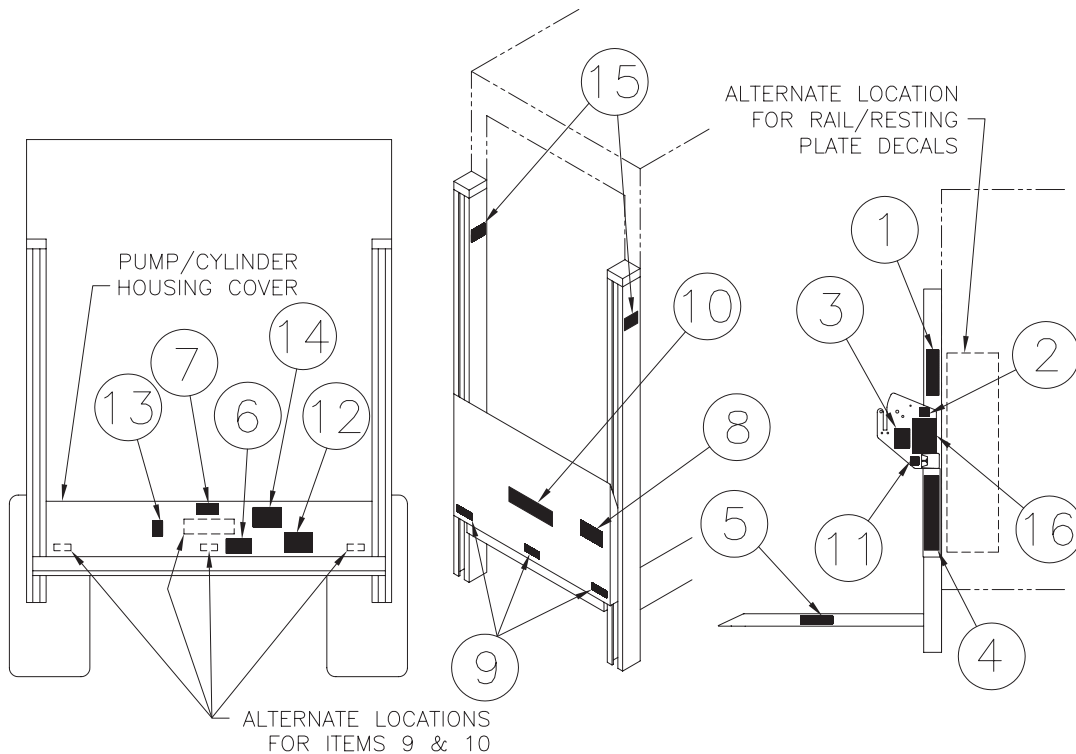

Item	Part Number	Description	Qty.	
			20	20A
1	31770-001	Main frame 80(56"BH)	1	
1	31770-002	Main frame 90(56"BH)	1	
1	31770-003	Main frame 95(56"BH)	1	
1	31770-004	Main frame 100(56"BH)	1	
1	31770-005	Main frame 80(46"BH)		1
1	31770-006	Main frame 90(46"BH)		1
1	31770-007	Main frame 95(46"BH)		1
1	31770-008	Main frame 100(46"BH)		1
2	4473	Power unit	1	1
3	42006	Cylinder assembly	1	1
3	42017	Cylinder assembly (80W)	1	1
4	4420409	Breather cap	1	1
5	4930-001	MJ-MAORB 90°	1	1
6	4951-002	.25 Hose assembly	1	1
7	4931-001	Restrictor MJ-MAORB 90°	1	1
8	4350	Cable Lug #2	1	1
9	8101-001	Clevis pin	1	1
10	5700022	Hairpin cotter	1	1
11	8120388	.38 Flatwasher	2	2
12	8120382	.38 Lockwasher	2	2
13	8180126	.38 x 1.50 Screw	2	2
14	4318-002	Battery cable	1	1
15	4477	Solenoid	1	1
16	31558	Cylinder Retainer Weld	1	1
17	8180022	.25 x 1 Screw	4	4
18	8120380	.25 Lockwasher	4	4
19	8120375	.25 Nut	4	4
20	5701960	Grommet	3	3
21	8456922	.50 x 1.50 carriage bolt	2	2
22	2103160	Locking cam	2	2
23	8120396	.50 Flatwasher	2	2
24	8103-021	.50 Lock nut	2	2
25	31765	Roller housing weld	2	2
26	5793010	.25 x .75 Screw	8	8
27	3109140	Latch cable assembly	2	2
28	4300030	Battery cable 25'	1	1
29	4318-003	Battery Cable #2 x 5'	1	1
30	31447	Toggle switch Asm	1	1
31	4301290	Wiring harness	1	1
32	5791	Resting Plate Pad	2	2
33	8111-005	Screw #10 x .75	2	2
34	4319-002	Heat Shrink	1	1
35	4318-001	Battery Cable #2 x 2'	1	1
36	4301770	Circuit Breaker	1	1
37	8120386	Flat Washer	4	4
38	4309	Pendant Control	1	1
39	4301342	Receptacle	1	1

LIFTING CHAIN ASSEMBLY

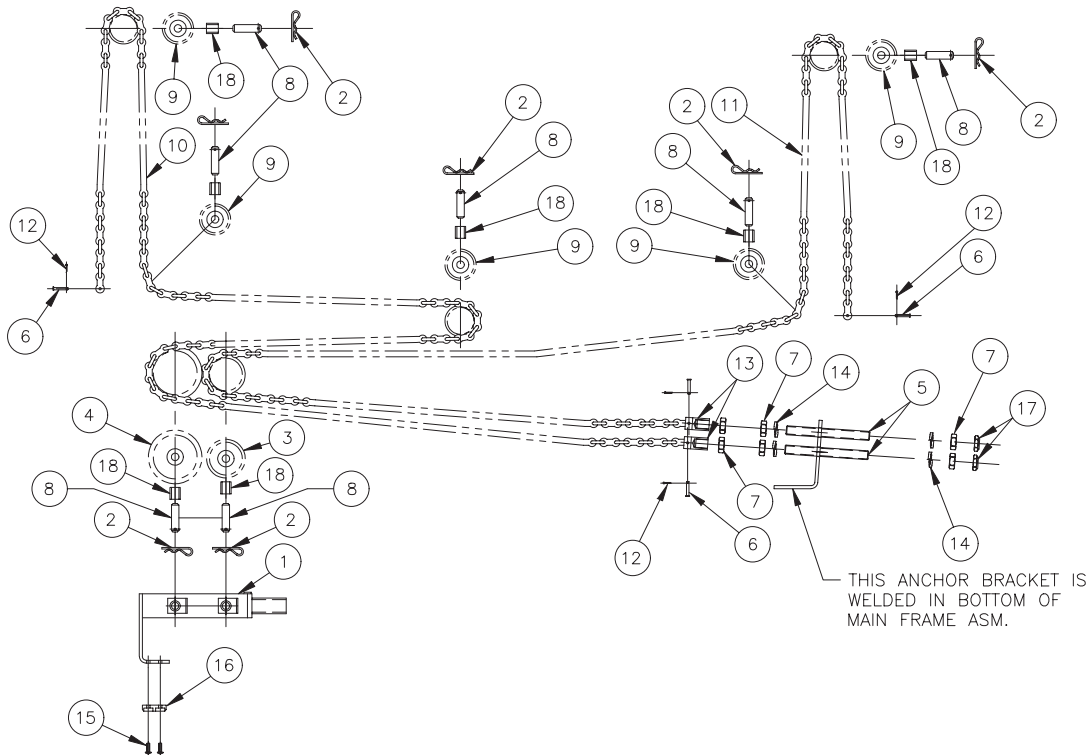

Item	Part Number	Description	Qty.	
			20	20A
1	3109576	Pusher Weld	1	1
2	5700022	Hairpin Cotter	7	7
3	31213-002	3.25 Chain Roller Asm (inc item 18)	1	1
4	31213-003	4.50 Chain Roller Asm (inc item 18)	1	1
5	5084-001	Tension Rod	2	2
6	2502100	Chain Anchor Pin	4	4
7	8219758	.75 Jam Nut	6	6
8	5067	Pin	7	7
9	31213-001	2.63 Chain Roller Asm (inc item 18)	5	5
10	4107-004	Chain SS 90 (56" BH)	1	
10	4107-005	Chain SS 95 (56" BH)	1	
10	4107-006	Chain SS 100 (56" BH)	1	
10	4107-010	Chain SS 90 (46" BH)		1
10	4107-011	Chain SS 95 (46" BH)		1
10	4107-012	Chain SS 100 (46" BH)		1
10	4107-002	Chain SS 80 (56" BH)	1	
10	4107-008	Chain SS 80 (46" BH)		1
11	4107-001	Chain CS 80 (56" BH)	1	
11	4107-007	Chain CS 80 (46" BH)		1
11	4107-003	Chain CS 90,95,100 (56" BH)	1	
11	4107-009	Chain CS 90,95,100 (48" BH)		1
12	8116-001	Cotter Pin	4	4
13	2350001	Chain Anchor Housing	2	2
14	8106-005	.75 Lockwasher	4	4
15	8449646	Self Tapping Screw	2	2
16	5703	Wear Pad	1	1
17	8103-029	Hex Jam, Nylon Locknut .75	2	2
18	5504-008	Bushing	7	7

SLIDER ASSEMBLY

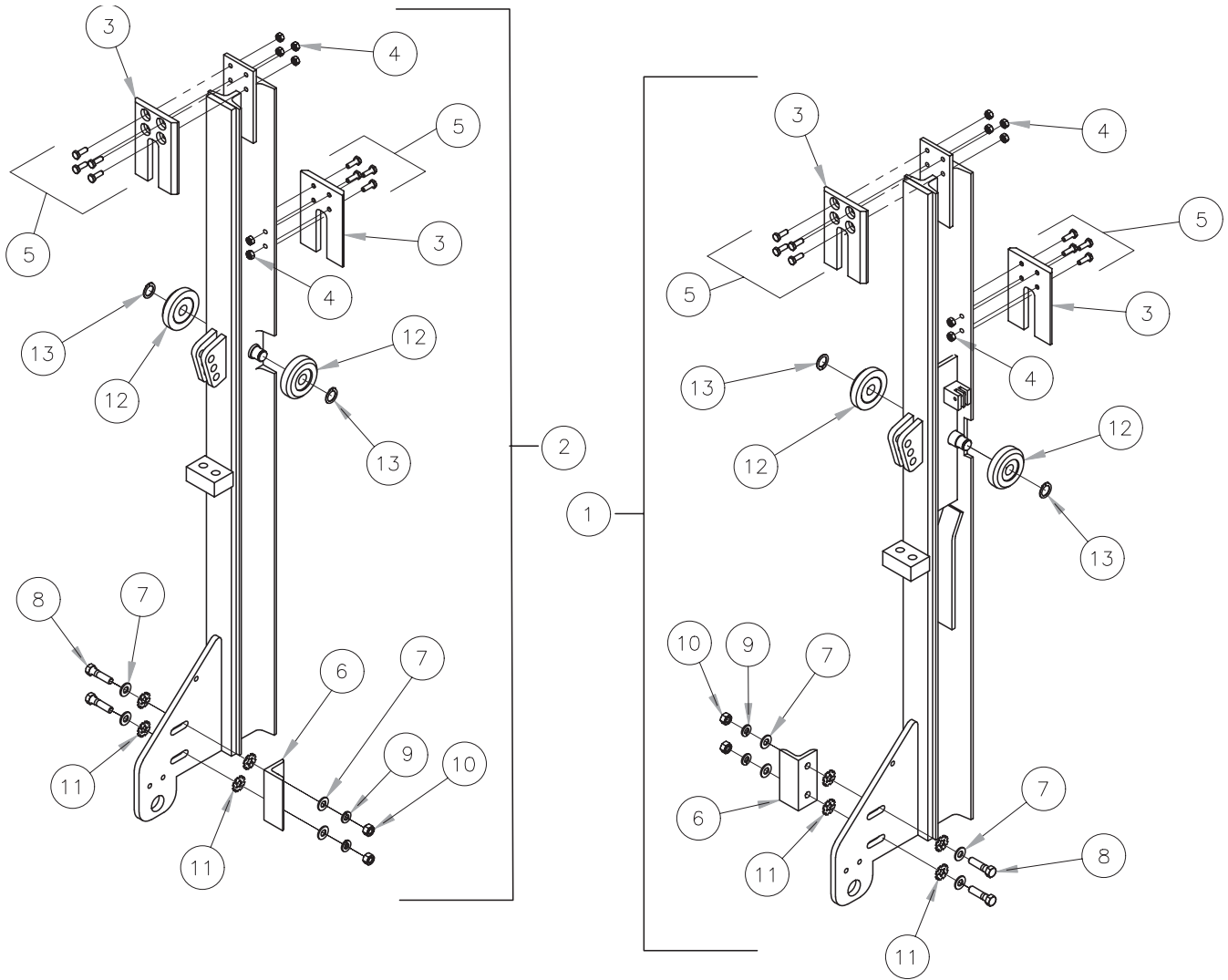

Item	Part Number	Description	Qty.
1	31809-002	Slider Asm RH	1
1	31809-004+	Slider Asm RH-Spring	1
2	31809-001	Slider Asm LH	1
2	31809-003+	Slider Asm LH-Spring	1
3	5781	Front Wear Pad	4
4	8103-019	.25 Locknut	16
5	8109-012	Screw .25 x .75	16
6	2013	Adjustment Angle	2
7	8120388	.38 Flatwasher	8
8	8180126	.38-16 x 1.50 Screw	4
9	8120382	Lockwasher .38	4
10	8120377	.38-16 Nut	4
11	8106-016	.38 Int/Ext Tooth Lockwasher	8
12	3106470	Roller Asm	4
13	5781016	Retaining ring	4

+Used with aluminum platforms requiring a spring assembly.

STEEL PLATFORM ASSEMBLY

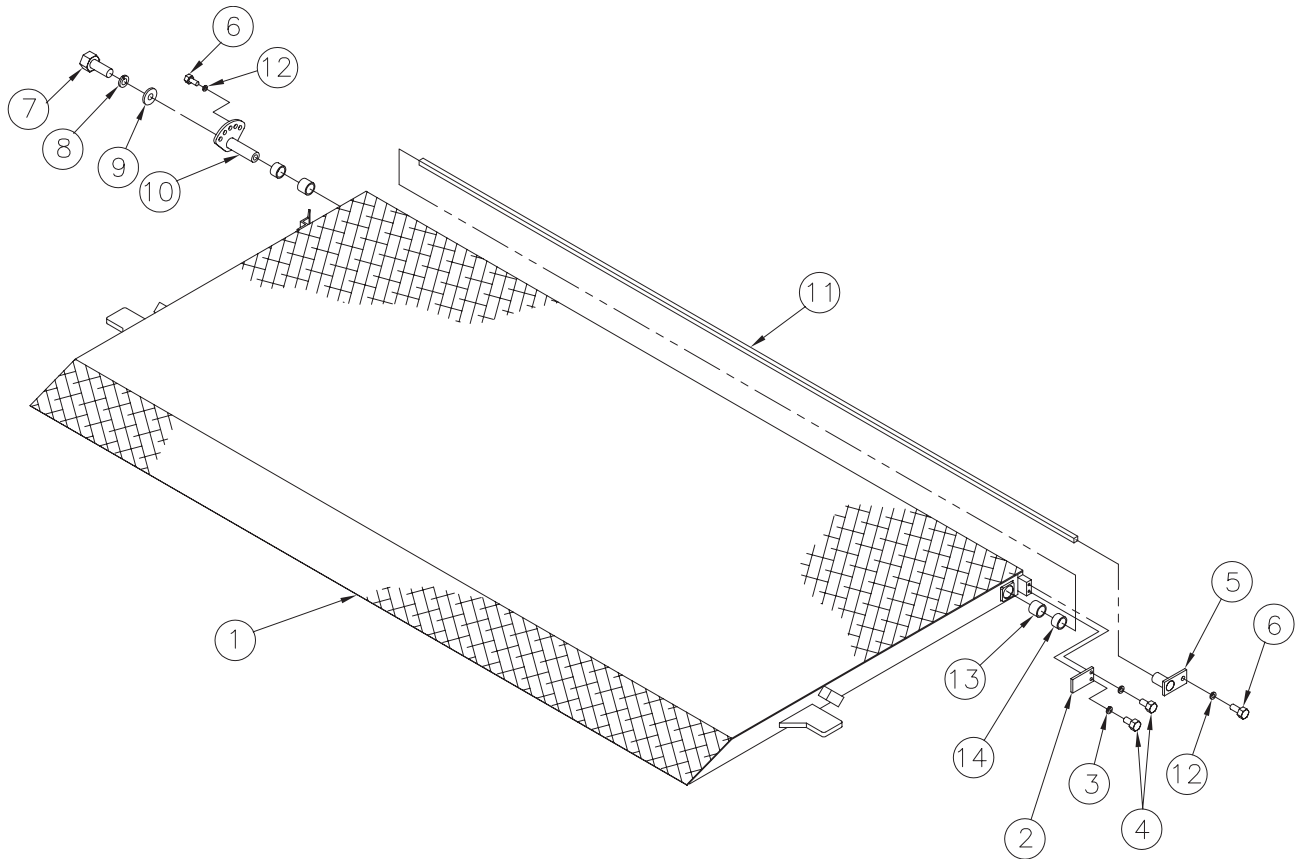

Item	Part Number	Description	Qty.
1	3408-001	7530 Platform	1
1	3408-002	7536 Platform	1
1	3408-003	7542 Platform	1
1	3408-004	8530 Platform	1
1	3408-005	8536 Platform	1
1	3408-006	8542 Platform (see note 1)	1
1	3408-007	9030 Platform	1
1	3408-008	9036 Platform	1
1	3408-009	9042 Platform (see note 1)	1
1	3408-010	9530 Platform	1
1	3408-011	9536 Platform	1
1	3408-012	9542 Platform (see note 1)	1

Item	Part Number	Description	Qty.
2	2329	Stop	1
3	8120380	.25 Lockwasher	2
4	8180022	.25 x 1.00 Screw	2
5	3199	Pin retainer	1
6	8180120	.38 x .75 Screw	2
7	8271713	.62 x 1.00 Screw	1
8	8121574	.62 Lockwasher	1
9	8130999	.62 Flatwasher	1
10	3108980	Adjusting bracket	1
11	5101-001	Torsion bar 85" platform	1
11	5101-002	Torsion bar 90" platform	1
11	5101-003	Torsion bar 95" platform	1
11	5101-004	Torsion bar 75" platform	1
12	8120382	.38 Lockwasher	2
13	5504-005	Bushing	2
14	5504-001	Bushing	2

Notes:

1. Requires one spring assembly and appropriate RH slider.

ALUMINUM PLATFORM ASSEMBLY

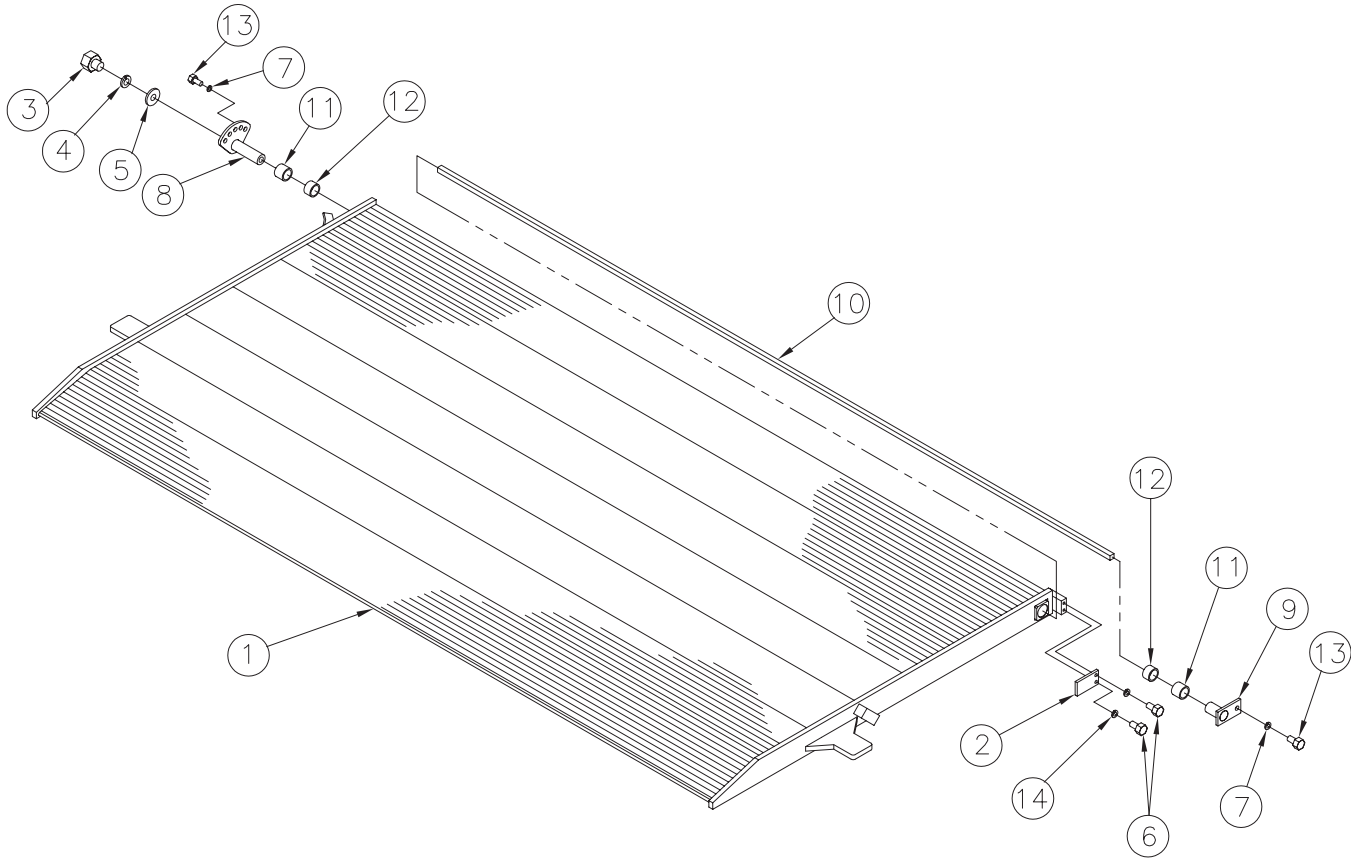

Item	Part Number	Description	Qty.
1	3407-001	7530 Platform	1
1	3407-002	7536 Platform	1
1	3407-003	7542 Platform	1
1	3407-004	7548 Platform	1
1	3407-005	7554 Platform	1
1	3407-006	7560 Platform	1
1	3407-007	7566 Platform (see note 1)	1
1	3407-008	8530 Platform	1
1	3407-009	8536 Platform	1
1	3407-010	8542 Platform	1
1	3407-011	8548 Platform	1
1	3407-012	8554 Platform	1
1	3407-013	8560 Platform (see note 1)	1
1	3407-014	8566 Platform (see note 1)	1
1	3407-015	9030 Platform	1
1	3407-016	9036 Platform	1
1	3407-017	9042 Platform	1
1	3407-018	9048 Platform	1
1	3407-019	9054 Platform	1
1	3407-020	9060 Platform (see note 1)	1
1	3407-021	9066 Platform (see note 1)	1
1	3407-022	9530 Platform	1

Item	Part Number	Description	Qty.
1	3407-023	9536 Platform	1
1	3407-024	9542 Platform	1
1	3407-025	9548 Platform	1
1	3407-026	9554 Platform (see note 1)	1
1	3407-027	9560 Platform (see note 1)	1
1	3407-028	9566 Platform (see note 1)	1
1	3407-029	8572 Platform (see note 2)	1
1	3407-030	9072 Platform (see note 2)	1
1	3407-031	7572 Platform (see note 1)	1
1	3407-032	9572 Platform (see note 2)	1
2	2329	Stop	1
3	8271713	.62 x .75 Screw	1
4	8121574	.62 Lockwasher	1
5	8130999	.62 Flatwasher	1
6	8109-001	.25 x 1.00 Screw SS	2
7	8120382	.38 Lockwasher	2
8	3108980	Adjusting bracket	1
9	3199	Pin retainer	1
10	5101-001	Torsion bar 85" Platform	1
10	5101-002	Torsion bar 90" Platform	1
10	5101-003	Torsion bar 95" Platform	1
10	5101-004	Torsion bar 75" Platform	1
11	5504-001	Bushing	2
12	5504-005	Bushing	2
13	8180120	.38 x .75 Screw	2
14	8106-002	.25 Lockwasher SS	2

Notes:

1. Requires one spring assembly and appropriate RH slider.
2. Requires two spring assemblies and appropriate LH and RH sliders.

PLATFORM CHAIN ASSEMBLY

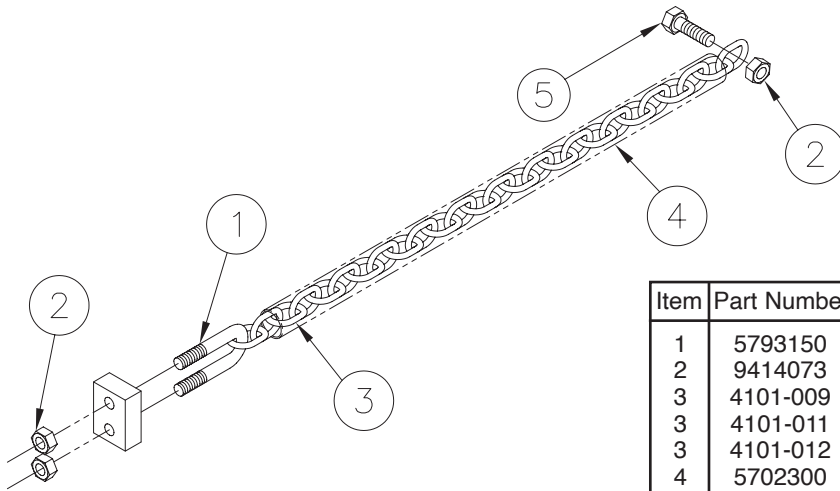

Item	Part Number	Description	Qty.
1	5793150	U-Bolt	2
2	9414073	.44 Locknut	6
3	4101-009	Chain 48,54" deep alum.	2
3	4101-011	Chain 60,66,72" deep alum.	2
3	4101-012	Chain 30,36,42" deep steel or alum.	2
4	5702300	Protective sleeve	2
5	5701910	.44 x 1.50 Bolt	2

SPRING ASSEMBLY

Item	Part Number	Description	Qty.
1	5793150	U-BOLT	1
2	9414073	Locknut	2
3	5101120	Spring	1

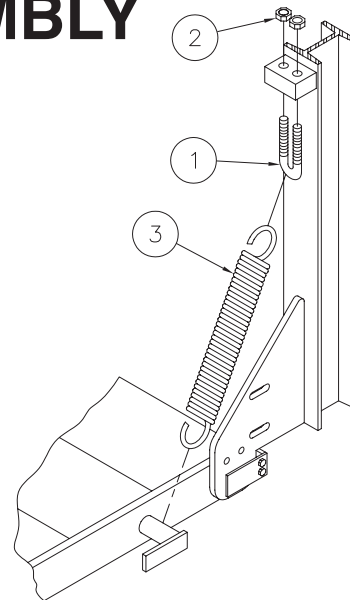

DAMPER ASSEMBLY

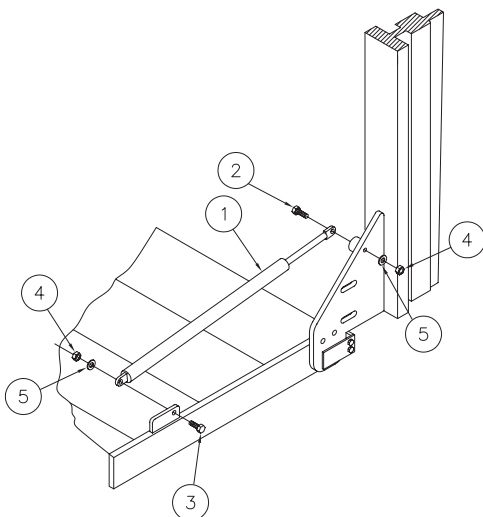

Item	Part Number	Description	Qty.
1	5770	Hyd. Damper	1
2	8104-004	Screw .31-18 x 1.75	1
3	8104-012	Screw .31-18 x 1	1
4	8103-013	Locknut .31-18	2
5	8107-004	Flatwasher .31	2

HOUSING COVERS

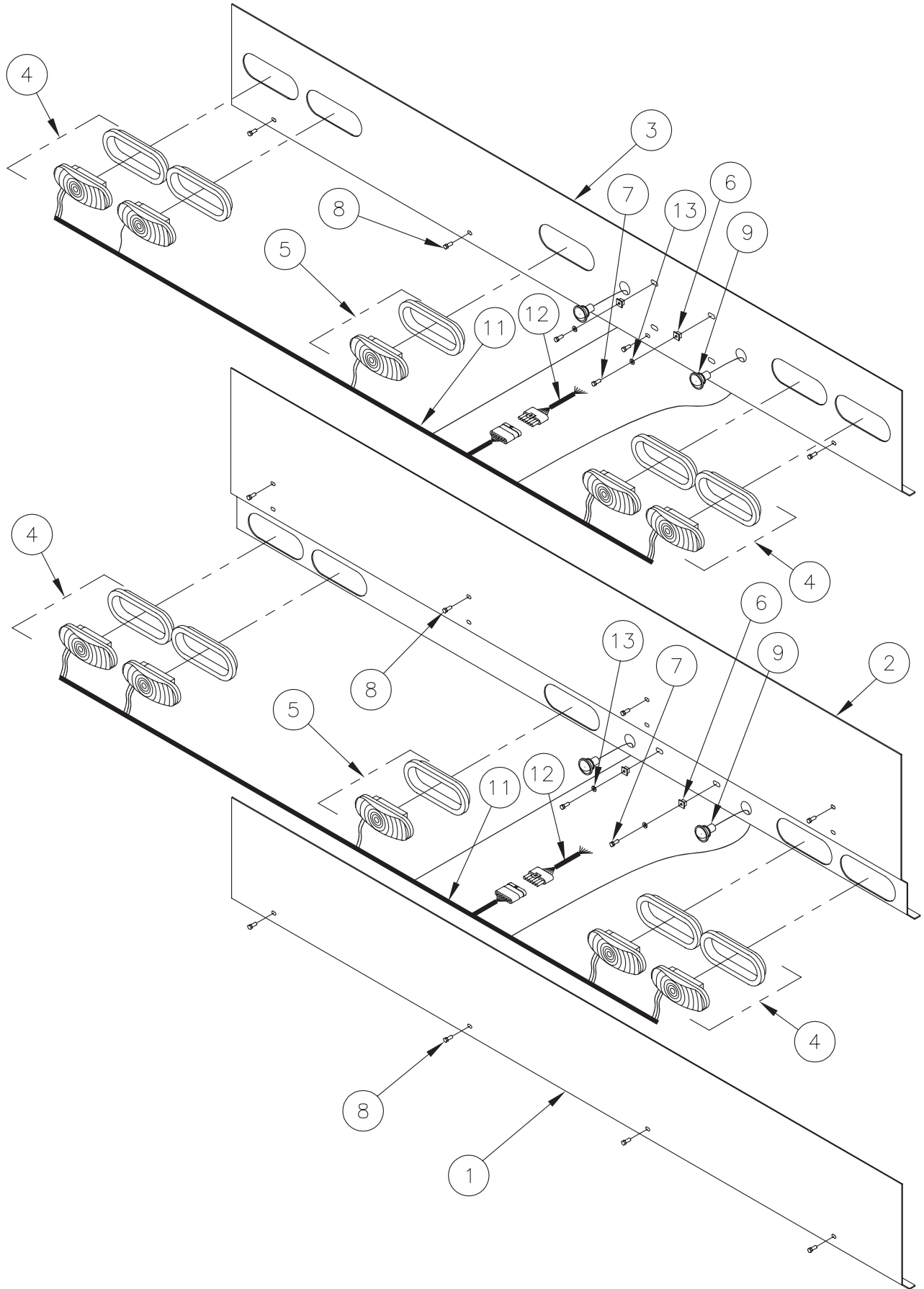

Item	Part Number	Description	Qty.	
			20,	20A
1	2714-001	Steel Cover 80	1	1
1	2714-002	Steel Cover 90	1	1
1	2714-003	Steel Cover 95	1	1
1	2714-004	Steel Cover 100	1	1
2	2715-001	Steel Cover 80 W/Lower Lights*	1	1
2	2715-002	Steel Cover 90 W/Lower Lights*	1	1
2	2715-003	Steel Cover 95 W/Lower Lights*	1	1
2	2715-004	Steel Cover 100 W/Lower Lights*	1	1
3	27158-001	Steel Cover 80 W/Upper Lights		1
3	27158-002	Steel Cover 90 W/Upper Lights		1
3	27158-003	Steel Cover 95 W/Upper Lights		1
3	27158-004	Steel Cover 100 W/Upper Lights		1
3	2711411	Alum. Cover 80 W/Upper Lights		1
3	2711412	Alum. Cover 90 W/Upper Lights		1
3	2711413	Alum. Cover 95 W/Upper Lights		1
3	2711414	Alum. Cover 100 W/Upper Lights		1
4	31475	LED Stop/Turn/Taillight	4	4
5	43060	LED Back-up light	1	1
6	5702270	Plastic square nut	2	2
7	5702280	Screw	2	2
8	5793010	.25 x .62 Screw	4	4
9	4300550	License plate light	2	2
10	5792020	Gasket (not shown)	1	1
11	4308	Taillight Wiring Harness	1	1
12	4368	Taillight Wiring Harness	1	1
13	8107-007	Flatwasher	2	2

*Not for use on Low Bed applications

CAM CLOSE ASSEMBLY

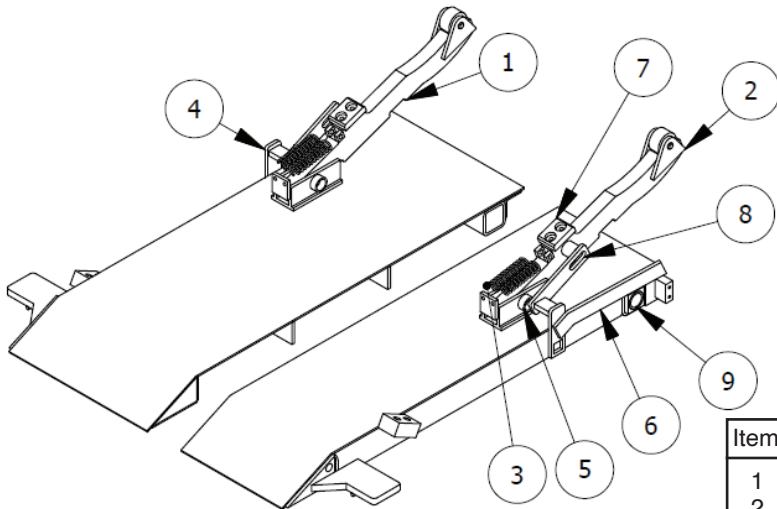

Item	Part Number	Description	Qty.
1	31449-001	Cam Follower Asm	1
2	31449-002	Cam Follower Asm	1
3	5108	Spring	4
4	31460	Linkage Weld LH	1
5	5067	Pin	2
6	31459	Handle Weld RH	1
7	5510	Bearing	2
8	5703	Nylon Pad	2
9	2522-001	Cam Shafts	1
9	2522-002	Cam Shafts	1
9	2522-003	Cam Shafts	1
9	2522-004	Cam Shafts	1

ELECTRICAL PICTORIAL

GRAVITY DOWN ELECTRIC CONTROL (TOGGLE OR REMOTE PENDANT)

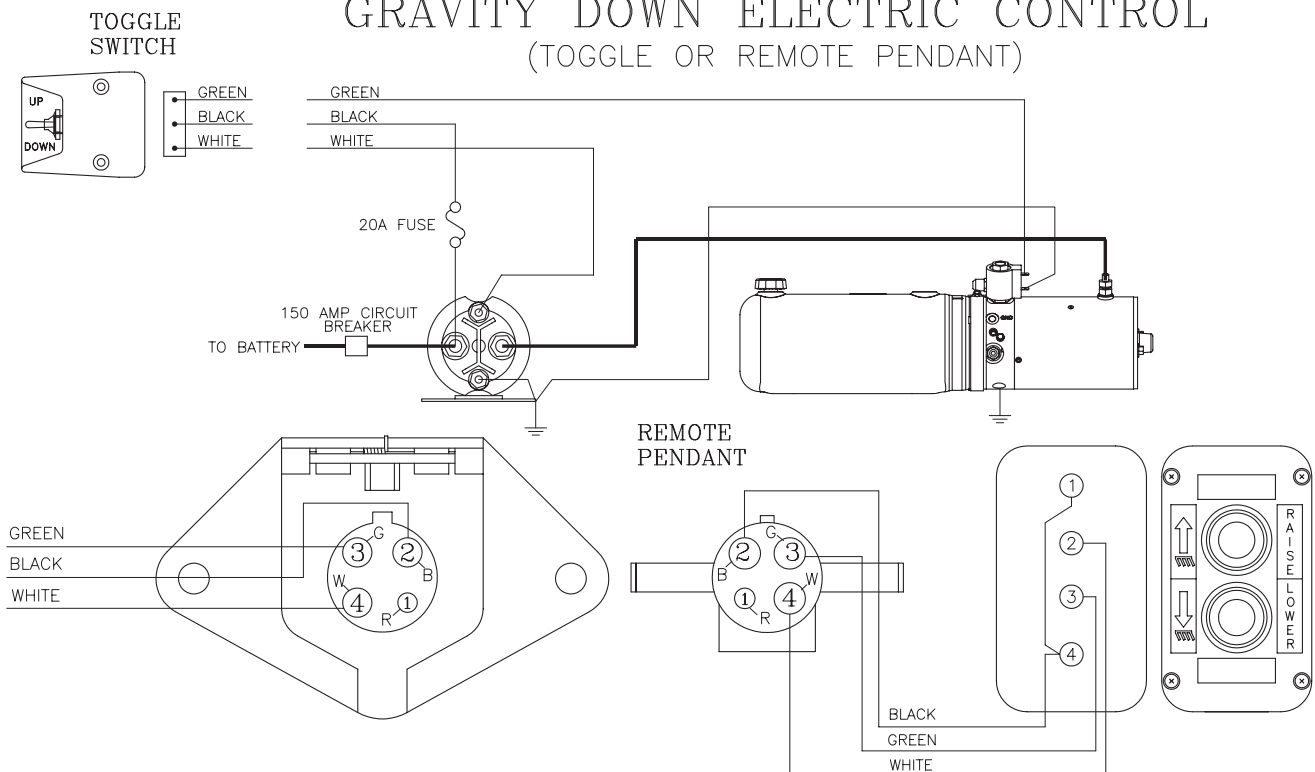

2 PC PLATFORM 3 FINGERED HINGE

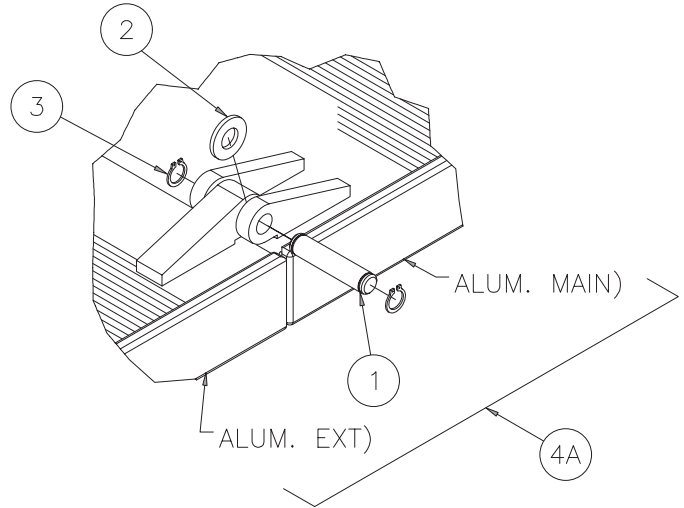
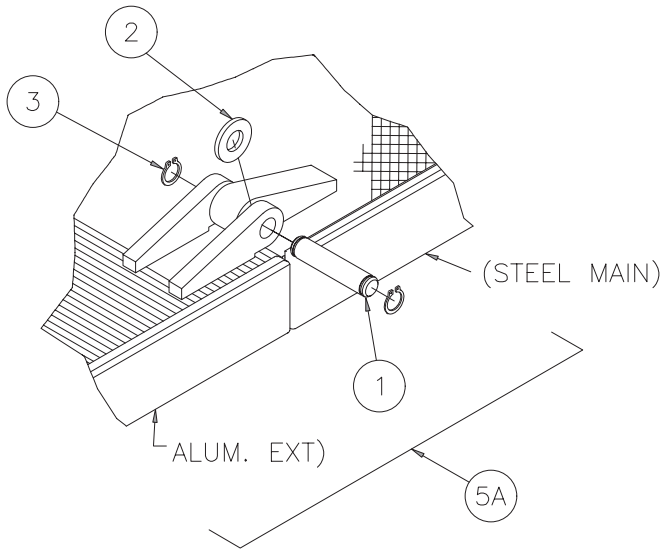

Item	Part Number	Description	Qty.
1	5056	Pin	1
2	8107-011	Washer	1
3	5781017	Snap Ring	2
4A	31277-001	Hinge Asm Alum Main/Alum Ext	1
4B	31277-002	Hinge Asm Alum Main/Alum Ext	1
5A	31279-001	Hinge Asm Steel Main/Alum Ext	1
5B	31279-002	Hinge Asm Steel Main/Alum Ext	1

RIGHT SIDE SHOWN - LEFT SIDE OPPOSITE

TROUBLESHOOTING GUIDE TVLR20 ET

- Test Equipment:**
1. 0-5000 psi pressure gauge
 2. DC voltmeter/ohm meter
 3. DC amp meter
 4. standard mechanics tools

Note: Please refer to the electrical diagrams and hose connection drawings in the liftgate's owner's manual when troubleshooting. This guide is only for standard Thieman liftgates. Special liftgates with options other than those in the owner's manual will require special diagrams for troubleshooting. Read and understand this entire guide completely before doing any troubleshooting. Certain listed problems may be related to other problems listed so a comprehensive knowledge is required before proceeding.

1. Problem - Pump motor will not run in the raise mode	
Cause	Correction
a. Tripped circuit breaker	Reset the circuit breaker located within 2ft of the liftgate supply battery(ies).
b. Blown 20A fuse	Replace 20A fuse (s). Each control cord should have a 20A in-line fuse on the black wire, where it connects to the 2ga. battery cable at the motor start solenoid.
c. Improper battery cable connection or improper ground connection	The "at rest" voltage for the batteries without the engine running and under no load should be at least 12.5V, and this voltage should be seen on the heavy 2ga. battery cable, where it connects to the large terminal of the motor start solenoid. The minimum voltage between the motor stud and ground is 10V at maximum conditions, with pump motor, batteries, and cables under max. load. If the voltage is dropping below 10V under max. load, bad connections may be acting like resistors and causing larger voltage drops than expected. Check voltage drops with system under load at different locations between the liftgate and battery source, to locate bad connections along the battery cable. Trace ground cable connections also to locate improper connection(s) along the ground path. Make sure the ground cable is installed going from the 5/16 tapped hole in the aluminum pump base marked GND to the liftgate mounting plate (scrape paint to bare metal for good ground). The ground cable from the batteries to the frame must be a heavy 2ga. cable that is connected to bare metal on the frame. Replace any damaged cables and repair any bad connections
d. Defective or undercharged battery(ies)	If proper voltage is not present, load test batteries and replace any defective batteries. The battery(ies) on the vehicle should be that which has a minimum 180-amp reserve capacity.
e. Defective or improperly wired raise switch	Check voltage on the black wire of the control cord near the switch. If no voltage is present the black wire from the motor start solenoid is loose or broken and needs repaired. If voltage is present then check for voltage at the white wire on the switch with the switch in the "UP" position. If no voltage is present, replace the switch.
f. Defective or improperly wired solenoid start switch	Check for voltage on the white wire at the motor start solenoid when the switch is activated "UP". If no voltage exists the white wire is loose or broken between the switch and the motor start solenoid. Check that the purple ground wire on the start solenoid is connected properly and there are no bad connections. If there is voltage on the white wire and the coil does not energize or if there is no voltage on the motor side of the solenoid or a large voltage drop present across the large terminals of the motor start solenoid then replace the motor start solenoid.
g. Defective pump motor	With the switch activated in the "UP" position and the motor start solenoid activated, check for voltage (10V minimum) at the motor terminal. If proper voltage is present and the motor is not running, double check the motor ground (see correction c. above.). If the motor has proper voltage and good ground and does not run, replace the motor.

<p>2. Problem - Liftgate will not raise or raises slowly with a load and the pump motor running. The raise speed of the TVLR20 from ground on a 56" bed height while empty at 70° F is approximately 18-20 seconds. The raise speed loaded for the same conditions is approximately 28-30 seconds.</p>	
Cause	Correction
a. Low hydraulic fluid	Make sure the reservoir has the proper amount of fluid. The hydraulic fluid should be within ½" of the top of the reservoir with the liftgate in the lowered position. Fill with Dexron III automatic transmission fluid or other acceptable fluid (see Hydraulic Fluid Chart in "Maintenance Guide" section of this manual). Low fluid levels can introduce air, which will compress, especially when loaded and can make the liftgate feel "spongy". It can also make the gate raise at varying and alternating speeds (i.e. slower as the air is compressed, then suddenly quicker as the air expands in a repeating pattern).
b. Cold Weather	Refer to Hydraulic Fluid Chart in "Maintenance Guide" section of this manual, for alternative oils to use for cold weather conditions
c. Overload condition	The power unit on the TVLR20 is equipped with a lifting relief valve to prevent overloading of the liftgate while attempting to raise a load. See relief setting in "Maintenance Guide" section of this manual. Do NOT overload the liftgate.
d. Low voltage and/or bad ground	If the voltage reaching the motor drops below 10V under max. load conditions, this low voltage can cause the liftgate to slow. If voltages get low enough or ground is inadequate, the liftgate may not raise at all (see Problem 1) and will not be able to develop the rated relief pressure. Low voltages can cause motor start solenoids to overheat and internally weld the contacts closed, which can lead to motor overheating and pump failure. DO NOT run the liftgate under low voltage/and or bad ground conditions.
e. Improperly adjusted or defective main relief valve	See section "c" above for relief valve setting. Lower the gate completely to the ground to relieve all pressure from the hydraulic system and remove all loads from the platform. Plumb a pressure gauge into the high-pressure circuit of the liftgate (the high-pressure hoses connected to the port on the pump). Engage the "UP" switch until the liftgate is fully raised. Keep the "UP" switch engaged until the pump bypasses through the relief valve and note the pressure on the gauge at this time. If the rated relief pressure is not present during relief, adjust the high-pressure relief valve setting as necessary. If the relief pressure is not attainable, the relief valve must be cleaned and/or replaced or the pump is defective. See part i below.
f. Lift cylinder is bypassing, liftgate is drifting down too quickly	If the liftgate will not raise with a load on the platform, or raises slowly or only partially when empty, the cylinder may be bypassing. A bypassing cylinder will cause increased hydraulic drift in the liftgate. The TVLR20 liftgate's maximum allowable drift is .31 inch/hr. (the platform can lower .31 inch/hr). To check for a bypassing cylinder, do the following: Lower the gate to the ground to relieve all pressure and remove the cylinder housing cover. Disconnect the cylinder from the pusher. Press the "UP" switch until the cylinder is fully extended. Press the "UP" switch for 15 to 20 seconds and watch for a steady stream of fluid coming out of the breather port (in lock-ring slot of cylinder on underside of barrel on rod end). Replace or rebuild any cylinder with fluid coming out of the breather port, as this indicates fluid bypassing the piston seals on the cylinder. Reconnect rebuilt or replaced cylinders and hoses as before.
g. Broken hydraulic line	Broken or punctured hydraulic lines and fittings must be replaced with care to avoid injury from high pressure oil streams.
h. Clogged or disconnected suction line	With the liftgate at the ground, disconnect the power unit and remove the reservoir. Check to see if the suction tube is clogged or has fallen out of the pump base. Clean the screen or reattach the suction tube as required.
i. Defective pump	If all else fails, the power unit MAY be defective. If the liftgate is older, the pump may be worn out and unable to pump fluid at pressure with the correct flow rate. Feel free to contact Thieman for further consultation.

3. Problem – Liftgate will not lower	
Cause	Correction
a. Defective or improperly wired lower switch	Check voltage on the black wire of the control cord near the switch. If no voltage is present, the black wire from the motor start solenoid is loose or broken and needs repaired. If voltage is present, then check for voltage at the green wire on the switch with the switch in the “DOWN” position. If no voltage is present, replace the switch.
b. Defective lowering solenoid coil or valve	With the “DOWN” switch engaged, check for voltage on the green wire on the lower solenoid valve coil terminal. If no voltage is present, the green wire from the “DOWN” switch is loose or broken and needs replaced. Check for proper ground at the purple wire on the lowering solenoid coil. Repair or replace ground as required. If there is voltage (minimum of 9.5 volts) and proper ground at the lowering coil, and the valve is not opening to allow the gate to lower, either the lower coil is bad or the entire lower coil/valve assembly is bad. To check to see if the coil is defective, remove the green and purple wires from the spade terminals on the lower coil and check the resistance between these spade terminals (3.6 - 4.4 Ohm is acceptable). Note: Low resistance can cause the 20-amp fuse to blow (see Problem 1, part b) and high resistance will lower the coils magnetic force and may not shift the valve. If proper resistance does not exist, replace the defective coil, otherwise replace the defective lower coil/valve assembly.
c. Clogged or defective hydraulic lines, fittings or flow controls	Remove any obstruction in the hoses, fittings, and flow controls or replace any hose, fitting or flow control which does not allow fluid to flow through freely.
4. Problem – Oil or foamy oil/air mixture flowing from reservoir breather	
Cause	Correction
a. Air is present in the system	This can occur if air enters the system if the fluid level is low, see problem 2, part a, or if the suction tube is disconnected, see problem 2, part h. Also, air may enter through fittings which are not tightened properly, so check for any leaks around fittings or hoses. Once the source of the air is determined, the cylinder must be bled of all air. Most air can be removed from the system by lowering the gate to the ground to relieve all pressure from the cylinder, unpinning the cylinder, and cycling them back and forth several times from fully extended to fully retracted and allowing the pump to bypass through the relief valves for a few seconds in each direction.
b. Reservoir was overfilled or filled with liftgate in wrong position.	See the MONTHLY INSPECTION AND MAINTENANCE in the “Maintenance Guide” section of this manual to find out what position the liftgate should be in when checking the reservoir level and how full the reservoir should be in that position.
5. Problem – Platform difficult to unfold to horizontal position OR platform hard to fold up from horizontal position	
Cause	Correction
a. Torsion bar broke	TVLR20 liftgates are equipped with a torsion bar to assist unfolding and folding the platform. If the platform suddenly becomes heavier to fold and unfold, the torsion bar is likely broken. Replace the torsion bar if broken.
b. Platform pivot pins are seizing up in platform pivots	Check that the platform pivot pins turn freely in the platform pivots. Any tightness in these pivots will result in additional force required when folding or unfolding the platform. If the platform gradually became harder to fold and unfold, it is likely due to stiffness in the pivots. Replace worn bushings or corroded pins as necessary.

6. Problem - Liftgate chatters when raising or lowering	
Cause	Correction
a. Inadequate lubrication between sliders and rails	The rails should be lubricated on a regular basis. See Owner's Manual for the type and frequency of lubrication and the locations for lubricating. Lubricate each frame rail on 4 surfaces where slider wear pads or rollers make contact over the entire length of each rail. DO NOT USE GREASE!
b. Rail wear surfaces are dirty & contaminated	If lubrication of the rails does not eliminate the chattering it may be necessary to completely clean the rails, slider wear pads, and rollers. The sliders should be removed from the rails to thoroughly clean the rails, slider wear pads and rollers. All contaminants must be removed from the rail including grease, rust, paint overspray, etc., such that only bare metal remains. Lubricate the pads and rails before reassembly. See step C.
c. Wear pads are worn down or embedded with contaminants	If the wear pads are worn down to the mounting screw heads or if they are embedded with contaminants (rust, road debris, paint overspray, etc.), it will be necessary to replace them at this time.
d. Wear pad mounting screws are loose	The wear pads at the top of the sliders are secured using screws and center detent locknuts. Retighten locknuts or replace hardware if locknuts are no longer tight (locking) on screws. The lower wear pads below the rollers, use self-tapping screws. Apply a thread locker loctite to the threads of the screws and tighten.
e. Slider rollers are not turning freely	Make sure all slider rollers can be rotated by hand fairly easily. If a liftgate is older, the rollers may not spin like they are brand new, but they should turn fairly easily by hand. If a roller will not turn by hand, look for flat spots on the rollers or skid marks in the rails, which would further indicate the rollers are not turning freely. Replace any roller that does not turn freely.
f. Platform chains are not in equal tension	Adjust the platform support chains so they are in equal tension.

If you have any questions or problems that are not covered in this guide please call Thieman's Engineering Department at 1-800-524-5210.