

# STOWAWAY

Tailgates By THIEMAN

## M/MLB/MDC/MDC LB 25, 30 OWNERS MANUAL/PARTS LIST

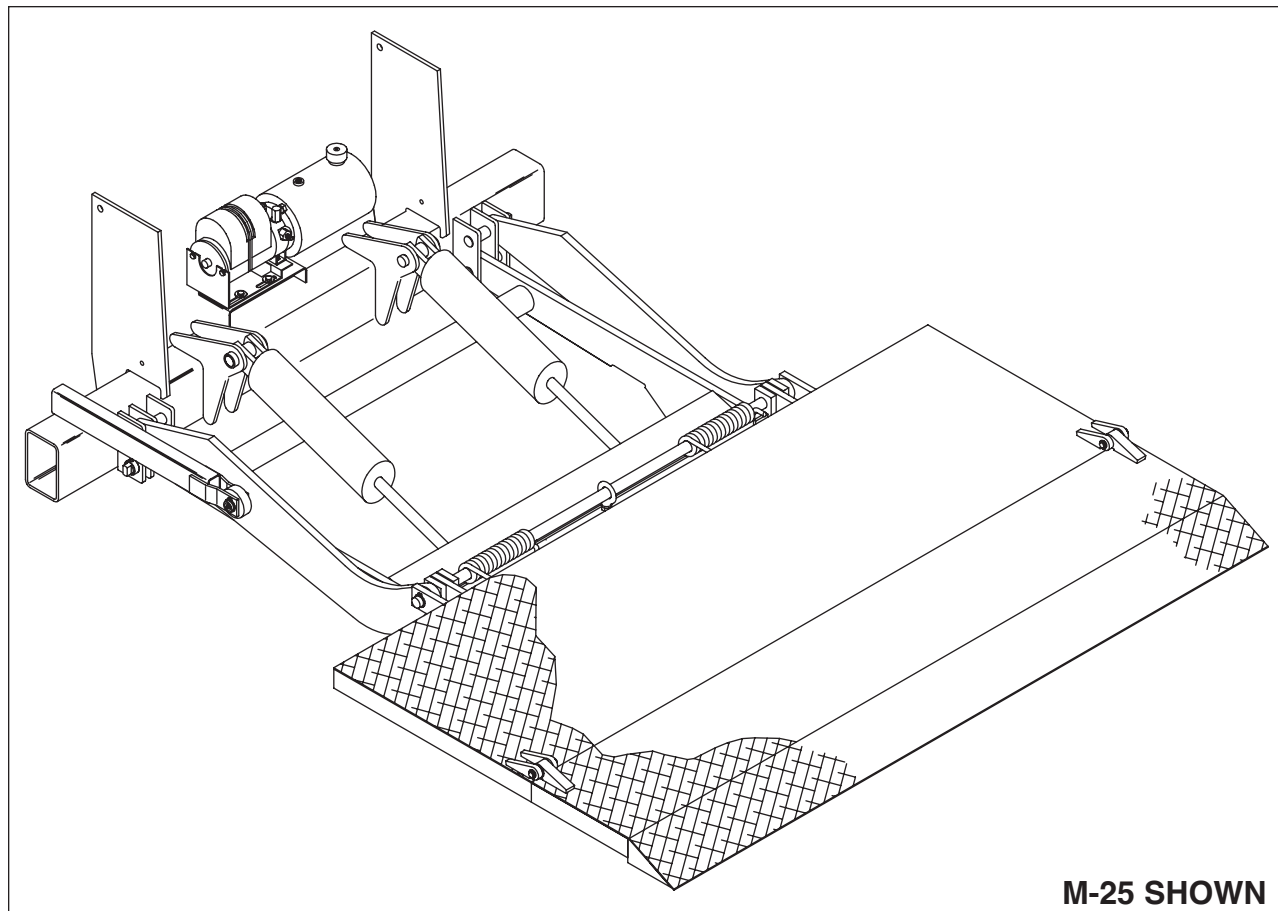

M-25 SHOWN



**IMPORTANT! KEEP IN VEHICLE!**

PLEASE READ AND UNDERSTAND THE CONTENTS OF THIS  
MANUAL BEFORE OPERATING THE EQUIPMENT.

**THIEMAN**  
TAILGATES, INC.

600 East Wayne Street  
Celina, Ohio 45822

Phone: 419-586-7727 Fax: 419-586-9724  
[www.thiemantailgates.com](http://www.thiemantailgates.com)

**NTEA**  
THE ASSOCIATION FOR THE WORK TRUCK INDUSTRY  
MEMBER

## TABLE OF CONTENTS

PARTS ORDERING PROCEDURE .....	2
SAFETY INFORMATION & WARNINGS.....	3-7
OPERATING INSTRUCTIONS.....	8
MAINTENANCE GUIDE & MONTHLY INSPECTION AND MAINTENANCE.....	9-10
SEMI-ANNUAL INSPECTION AND MAINTENANCE .....	10
DECAL MAINTENANCE - INSPECTION AND LOCATION OF DECALS .....	11
PLATFORM ASSEMBLIES (STEEL MAIN/EXT.) .....	12 thru 14
PLATFORM ASSEMBLIES (STEEL MAIN/ALUM EXT).....	15
PLATFORM ASSEMBLIES (ALUM. MAIN/EXT) .....	16 thru 19
SPACER ASM .....	20
TRUNNION, LIFT ARM, AND IDLER ARM ASM .....	21 & 22
ELECTRICAL PICTORIALS .....	23
M PUMP ASM ELECTRIC CONTROL .....	24 & 25
MDC PUMP ASM ELECTRIC CONTROL .....	26 & 27
PUMP PARTS.....	28 & 29
SNUBBER KIT.....	30
TROUBLESHOOTING GUIDE .....	31 thru 34

### FOR YOUR RECORDS

Model No. \_\_\_\_\_ Date Purchased \_\_\_\_\_

Serial No. \_\_\_\_\_

**NOTE: When Ordering Parts Be Sure To Include This Information!**

### PARTS ORDERING PROCEDURE

When ordering parts, please include all the information asked for below. If this information is not available, a complete written description or sketch of the required part will help Thieman identify and deliver the needed part to you.

#### THE FOLLOWING INFORMATION MUST BE INCLUDED:

1. Serial Number – Thieman liftgate serial numbers can be found on the tag located on the outside of the curb side mounting plate.
2. Model Number and Capacity.
3. Platform Size and Material – Steel or Aluminum.
4. Part number.
5. Description.
6. Quantity required.

## SAFETY INFORMATION



This is the safety alert symbol. This manual uses this symbol combined with the Signal Words below, which together, alert you of potential personal injury hazards. **Obey all safety messages throughout this manual, including those that follow the Signal Words below, to avoid personal injury or death.** Each Signal Word is explained below.

### SIGNAL WORDS used in this manual



## DANGER

**DANGER** – Indicates a hazardous situation which, if not avoided, will result in death or serious injury.

---

Related information will follow



## WARNING

**WARNING** – Indicates a hazardous situation which, if not avoided, could result in death or serious injury.

---

Related information will follow



## CAUTION

**CAUTION** – Indicates a hazardous situation which, if not avoided, could result in minor or moderate injury.

---

Related information will follow

# **WARNING**

**IMPROPER OPERATION OF THIS LIFTGATE MAY RESULT IN SERIOUS PERSONAL INJURY AND/OR DEATH.** DO NOT operate this liftgate unless you have been properly instructed and have read and understood the Owner's Manual and all of its warnings, operating instructions and all decals.

Operators of this liftgate **MUST** be at least 18 years old. Do **NOT** allow those younger than 18 to be on or around the liftgate or to operate the liftgate.

ALL Liftgates, regardless of manufacturer or model, are mechanical devices, with components that can fail unexpectedly, due to abuse/misuse, poor maintenance, unforeseen causes, etc.

**Component failure can lead to sudden drops or tilting of the loading surface, resulting in loads falling or tipping without warning and this FACT, should ALWAYS be considered, when operating or around any liftgate.** The warnings and decals included with this liftgate, are designed to reduce exposure to these risks, for operators and bystanders.

**The following list of warnings is to be read and understood before operating the M/MDC 25/30 series liftgate.** The numbered list begins below and continues on the following pages.

---

## **WARNINGS!**

1. DO NOT operate this Thieman liftgate without the Owner's Manual for this model present on the vehicle and without all decals present and legible, as guides for proper liftgate operation and maintenance (see the "Decal Maintenance - Inspection and Location of Decals" section of this manual). For replacement Owner's Manuals, decals, etc. call Thieman at 419-586-7727. For the latest manuals and warnings for each liftgate, visit our website at [www.thiemantailgates.com](http://www.thiemantailgates.com). Note: manuals and warnings update regularly.
2. The vehicle must be securely and properly braked on level ground before using the liftgate.
3. All protective covers and guards must be in place before operating the liftgate.
4. Before using liftgate, check for signs of improper maintenance or damage (unusual noises, vibrations, fails to operate freely, missing hardware, cracked welds...etc. See the sections in this manual with "Maintenance" in the title – refer to "Table of Contents" on Page 2). DO NOT use the lift if these are evident. Only an authorized Thieman distributor is qualified to do repairs on the liftgate. DO NOT attempt to do your own repairs or modify this liftgate. Altering this product will void all warranties and may damage the liftgate or even cause serious injury. If any repairs, adjustments, or maintenance not covered in this manual are required, contact your nearest Thieman distributor or call Thieman at 419-586-7727.
5. **THIS IS NOT A PERSONNEL LIFT.** Because of the pinch point between the platform and the truck, fall hazards, unstable loads, etc., riding the lift may cause severe personal injury or death. **ALWAYS** stay clear of the liftgate when in operation. Do **NOT** ride the liftgate.

(Warnings continued on following pages)

6. Make certain the areas, in which the platform will open or close, are clear before opening or closing the platform.
7. Use this liftgate ONLY for its intended purpose of loading/unloading cargo between truck bed and ground. It is NOT to be used for anything other than this. The ground is defined as the surface the truck is parked on.
8. DO NOT use this liftgate to load or unload cargo from any elevated surface such as a dock, sidewalk, raised concrete slab, etc. A truck's suspension WILL squat under load, and may cause loads to become unstable. Also, this effectively changes the "bed height" of the truck, so the liftgate may not function properly on an elevated surface and may bind and damage the liftgate. Additionally, if the ENTIRE liftgate platform is not supported by the elevated surface, this partially supported condition WILL create unintended loads on the liftgate components and MAY LEAD TO A SUDDEN LIFTGATE FAILURE.
9. DO NOT OVERLOAD THE LIFTGATE. Each liftgate has a specific maximum capacity for lifting and lowering. The standard maximum rated capacity of the M series liftgates differs with each model as follows:
  - M/MLB/MDC/MDCLB25 - 2500 lbs. Maximum Load
  - M/MLB/MDC/MDCLB30 - 3000 lbs. Maximum Load**WARNING note: Special options can lower the maximum rated capacities below those shown above.** Be certain you know what the maximum rated capacity is for your particular liftgate.
10. NEVER off-center the load on the platform, from side to side or away from truck as this may overload the liftgate. The center of weight of the load should NEVER be placed beyond the center of the platform load surface, away from truck. Loads should be placed close to platform edge nearest truck. See figure 1.
11. NEVER allow any part of the load to extend beyond the edges of the platform's flat load surface. Overhanging objects increase the risks of tipping loads due to unstable loading or snagging these objects on surroundings and THESE OBJECTS COULD ALSO STRIKE OR CRUSH OPERATORS OR BYSTANDERS.
12. NEVER step on or place loads on, the ramp portion of any liftgate platform (includes all ramp styles), unless the platform is lowered completely to the ground and the entire platform and ramp are supported by the ground.
13. NEVER lift or lower unstable loads. NEVER attempt to grab or retain a load that is tipping, falling, or rolling off the platform, as you may fall with, and be crushed by, the load.
14. NEVER operate liftgate if platform load surface is slippery.
15. Make certain the areas above and below the liftgate platform and other moving liftgate parts, are clear before, and at all times during, operation of the liftgate. Do NOT allow anyone under a raised liftgate platform, where accidental or intended lowering could crush them. Do NOT allow anyone to stand around the platform where a falling load could land on them.

(Warnings continued on following pages)

16. When loading/unloading platform at ground level, load/unload the platform from the rear (ramp tip end). NEVER load/unload from the left or right sides of platform. Position loads on platform at ground level, considering how they can be later unloaded into truck most safely. For example, position loads on platform at ground, so loads are as near truck as possible, with any load handles within near reach of someone standing on the truck bed, once load is raised for unloading.
17. When moving cargo between truck bed and raised liftgate platform, make sure platform is level with truck floor. Keep your body entirely on truck bed when possible (avoid standing on liftgate platform when possible). For example, push loads from truck bed to liftgate platform. Avoid pulling loads from truck bed to liftgate platform, as this may place your body near the edges of the platform and increases your risk of falls and being crushed by the load. If it is necessary to temporarily stand on the liftgate platform, to safely position your load, keep yourself as close to the truck as possible and away from the outer edges of the platform, while following all other warnings in this manual.
18. Never operate lift trucks on or over any part of the platform.
19. Follow all sections in this manual with “Maintenance” in the title – refer to “Table of Contents” on Page 2.
20. NEVER move vehicle unless platform is properly stowed and power is off. An open liftgate on a moving vehicle poses a serious traffic hazard.
21. ALWAYS stow liftgate in transit position when not in use. Liftgates left in their open positions, may create hazards for people and vehicles passing nearby.
22. Take care to retain cargo during transit. Liftgates are not designed to retain objects on the truck. Improperly retained objects may fall from the vehicle and pose serious traffic hazards and larger objects could shift and damage the liftgate or truck.
23. Any time the vehicle is washed, this liftgate MUST be inspected to MAKE SURE all parts are properly lubricated and have the appropriate protectants. Failure to replace lubricants and protectants after washing the vehicle, may lead to improper operation of the liftgate, accelerated corrosion, and possible component failure.
24. NEVER operate the liftgate, while using a cell phone or while distracted. Safe liftgate operation, requires your full attention.

# **WARNING**

An improperly positioned load can overload the liftgate and result in sudden liftgate failure and/or increased risks to personnel of being hit or crushed by loads. **IMPROPERLY POSITIONED LOADS MAY RESULT IN SERIOUS PERSONAL INJURY AND/OR DEATH.** Always position loads properly on the liftgate platform. Follow information below on how to position loads properly.

## **POSITION LOADS PROPERLY ON PLATFORM**

NEVER off-center the load on the platform, from side to side or away from truck as this may overload the liftgate. The center of weight of the load should NEVER be placed beyond the center of the platform load surface, away from truck. Loads should be placed close to the platform edge nearest truck. If a load is not uniformly distributed, then the heaviest portion should be closest to the edge of the platform nearest the truck. NEVER allow any part of the load to extend beyond the edges of the platform's flat load surface. NEVER allow any part of the load to extend over or on, the tapered ramp portion of the platform unless the platform is lowered completely to the ground and the ramp is supported by the ground.

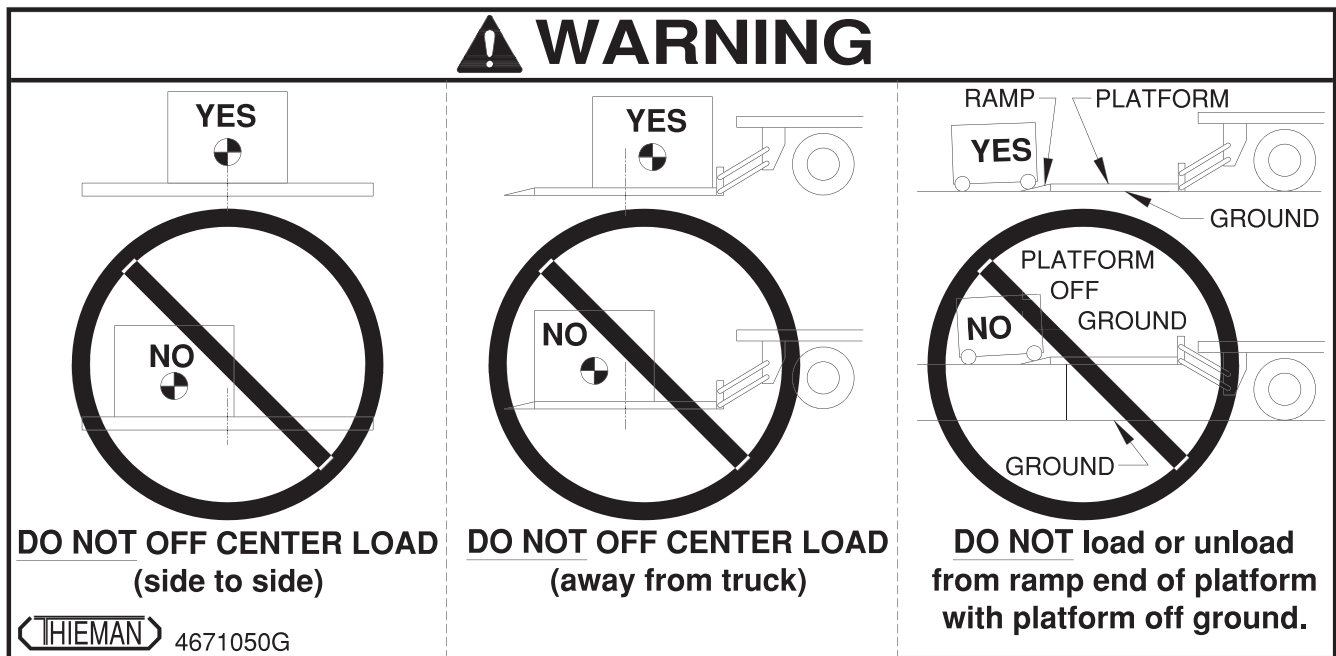

FIG. 1

## **DO NOT OVERHEAT THE HYDRAULIC PUMP**

Exceeding the duty cycle of the hydraulic pump, can overheat many components, including the gear pump, the hydraulic motor, the motor start solenoid, valve coils, etc., and significantly shorten the expected life of these components. In extreme cases, immediate damage to the pump or related components may occur. Refer to the Thermal data below.

**THERMAL DATA:** To avoid overheating the motor do not operate this unit for more than 5 cycles/ 10 minutes with the maximum load. The motor then must be allowed to completely cool down to ambient temperature before cycling the lift again. This unit also has a 10% duty cycle, which means the liftgate can be cycled no more than 2 cycles/10 minutes constantly with the maximum load.

# WARNING

**IMPROPER OPERATION OF THIS LIFTGATE MAY RESULT IN SERIOUS PERSONAL INJURY AND/OR DEATH.** DO NOT operate this liftgate unless you have been properly instructed and have read and understood the Owner's Manual and all of its warnings, operating instructions and all decals.

## OPERATING INSTRUCTIONS

### 1. UNLATCH

- Raise liftgate by pushing switch to UP position, until stow pin is off the spacer latch.
- Push spacer handle down with finger tips to disengage spacer latch and maintain this position through next step C.
- While holding spacer handle down, lower liftgate by pushing switch to DOWN position, until stow pin is clear of spacer latch. Release spacer handle.

(Curb side)

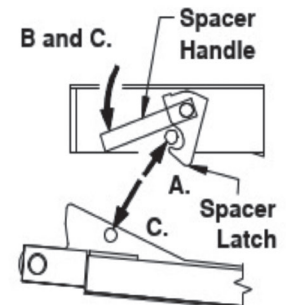

### 2. UNFOLD

- Lower liftgate by pushing switch to DOWN position, and stop once arms contact ground.
- Grasp curb side platform handle and rotate platform out to loading position.
- Unfold platform extension (and hinged retention ramp if so equipped).

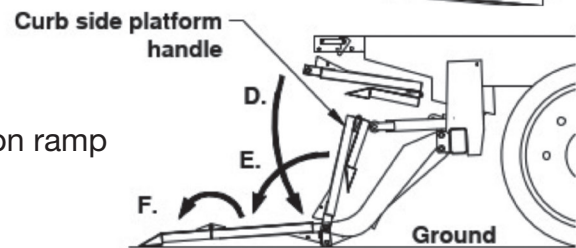

### 3. RAISE OR LOWER

- Push switch to UP position to raise liftgate.

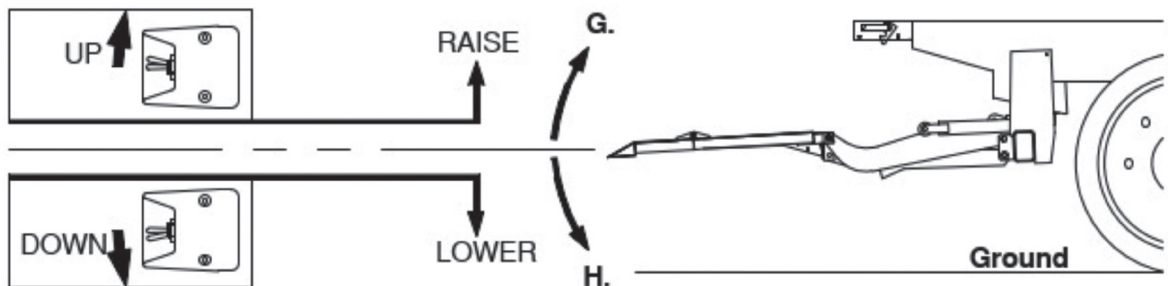

- Push switch to DOWN position to lower liftgate.

### 4. STORE FOR TRANSIT

- Lower liftgate by pushing switch to DOWN position, until arms are on the ground.
- Fold platform extension over on top of main section of platform, by grasping end of extension (For platforms with flip retention ramps, fold and secure them for transit, before beginning this step). On wedge style platforms, use curb side extension handle provided.
- Lift from underside of platform and fold entire platform upward. Grab platform handle on curb side to lower platform inward against nylon kicker roller.
- Raise liftgate by pushing switch to UP position.
- Continue raising liftgate until it stops against the underside of the spacer. **MAKE SURE** stow pin is engaged in spacer latch for transit. **DO NOT** lower stow pin on latch.

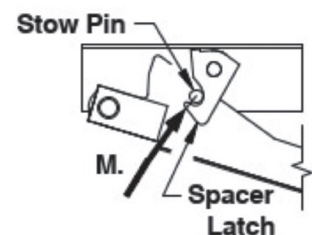
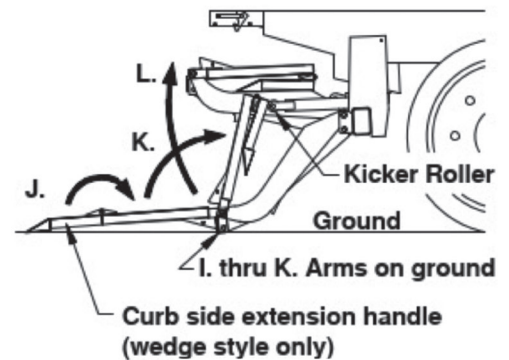

# **WARNING**

**IMPROPER MAINTENANCE OF THIS LIFTGATE MAY RESULT IN SERIOUS PERSONAL INJURY AND/OR DEATH.** Never use a liftgate, that has not been properly maintained. Follow all maintenance outlined in this manual, beginning with “Maintenance Guide” thru and including “Decal Maintenance - Inspection and Location of Decals”.

## **MAINTENANCE GUIDE**

The following inspection and maintenance operations should be performed at the recommended intervals or anytime the liftgate shows signs of abuse, and improper or abnormal operation.

### **MONTHLY INSPECTION AND MAINTENANCE**

Operate the liftgate throughout its entire operational cycle and check the following:

1. Check that there are no unusual noises or vibrations.
2. Check platform height relative to bed height. If platform is lower, adjust cylinder with a 13/16 wrench to obtain the necessary height.
3. Check for apparent damage to the liftgate such as bent or distorted members, any cracked welds that may have resulted from overloading or abuse.
4. Check for excessive wear in the following pivot areas (Note: For bushed pivots, if the gap between pin and bushing exceeds 1/32 of an inch, the bushing should be replaced. For pivots without bushings, replace worn components if gap between pin and pivot exceeds 1/32 of an inch. Refer to parts breakdown in this manual):
  - A. Platform hinge pins, bushings and extension pivots.
  - B. Cylinder pins, bushings and clevis.
  - C. Pins and bushings joining lift arm and idler arms to trunnion, platform and pivot bar.
  - D. Kicker arm pins, bushing, white nylon roller, etc.
  - E. Stow pins.
5. Check that ALL pins, bolts, hardware, etc. are in place and retained by their proper retainers.
6. Check that all protective covers and guards are properly in place and secured.
7. Check for oil leaks in these areas:
  - A. Lift cylinder
  - B. Hydraulic hose-replace if it shows signs of wear or cracking.
  - C. Hydraulic fittings-tighten or replace as may be required to stop leakage
8. Check the oil level in the pump reservoir. With the liftgate in the lowered position and the platform at ground level the oil should be within 1/2” from the top of the reservoir. See chart below for oil applications.
9. Check that all wiring and battery cable connections are tight and free of corrosion.
10. Lubrication of the M series liftgate should be as follows for all user conditions:

<u>Area of Tailgate</u>	<u>Type of Lubrication</u>	<u>Frequency</u>
Kicker roller asm	Grease	50 cycles
Pump oil change	see chart below	yearly
Control handle pivots	SAE 10 or 20 oil	50 cycles
Platform extension pivots	SAE 10 or 20 oil	50 cycles

The major pivot points of the M series liftgate have special bushings that do not require lubrication.  
For -40 to 120 F use #0 Grade grease.  
For -20 to 200 F use #1 Grade grease.

HYDRAULIC FLUID CHART	
Temperature Range	Acceptable Fluids
-45° F to 155° F	Mobil Univis HVI-26
0° F to 140° F	Dexron VI (or Dexron III) Mobil 1 Synthetic ATF Shell Spirax S6 ATF X
-55° F to 100° F	AeroShell Fluid 41 Mobil Aero HF Mobil Univis HVI-13 MIL-PRF-5606J

11. Check the pump relief pressure and also the motor amperage at this pressure. These values should be as follows:

<u>Model</u>	<u>Max. Amp. Draw</u>	<u>Relief Pressure (psi)</u>
M/MLB 25/30 ET	205	2500
M/MLB 25/30 EST	255	2650
MDC/MDCLB 25/30 ET	180	2000
MDC/MDCLB 25/30 EST	215	2000

### Semi-Annual Inspection

1. Perform the procedures outlined in the Monthly Inspection and Maintenance.
2. Repaint original painted components as necessary to prevent rust and corrosion from reducing structural integrity of original components.
3. Inspect pump motor by:
  - A. Disconnecting battery cable
  - B. Remove motor end cover
  - C. Examine the armature brushes for wear. (Brushes should be replaced if they are less than 1/8" long).
  - D. Clean all residue out from inside of the motor housing.
  - E. Apply several drops of light weight machine oil to the armature shaft bearing in the motor end cover and reassemble the motor end cover.
4. If the hydraulic oil in the reservoir is dirty:
  - A. Unfold platform and lower platform to the ground.
  - B. Drain the oil from the hydraulic system and flush the entire system.
  - C. Remove reservoir from pump and clean suction line filter. Also clean out any contaminants inside reservoir. Remount reservoir when completed.
  - D. Replace the oil as outlined in Section 9 under Monthly Maintenance and Inspection.

## DECAL MAINTENANCE - INSPECTION AND LOCATION OF DECALS



**IMPROPER OPERATION OF THIS LIFTGATE MAY RESULT IN SERIOUS PERSONAL INJURY AND/OR DEATH.** Liftgate decals provide important information, which is vital for proper and safe operation of the liftgate. Replace any decals which are missing or which are not fully legible. **DO NOT operate liftgate unless all decals are legible and are properly located.**

### LIST OF DECALS AND LOCATIONS

Item	Part Name	Part Number
1	Warning Decal-off center	4671050
2	Fast Idle Decal	4650150
2	PTO Decal	4650140
3	Danger Decal-no riding	4609
4	Operating Decal	4650890
5	Capacity Decal-2500#	4650110
5	Capacity Decal-3000#	4650120
6	Warning Decal-pinch point	4604
7	Handle Decal	4605
8	Thieman Nameplate	4650800
9	Urgent Warning Decal	4650530
10	Reflector (3)	5705
11	Wiring Decal-Gravity Down	4612
11	Wiring Decal-Power Down	4614
12	Warning Decal	4620
13	Caution Decal	4650770
14	Receiver Latch Decal (Optional)	4683

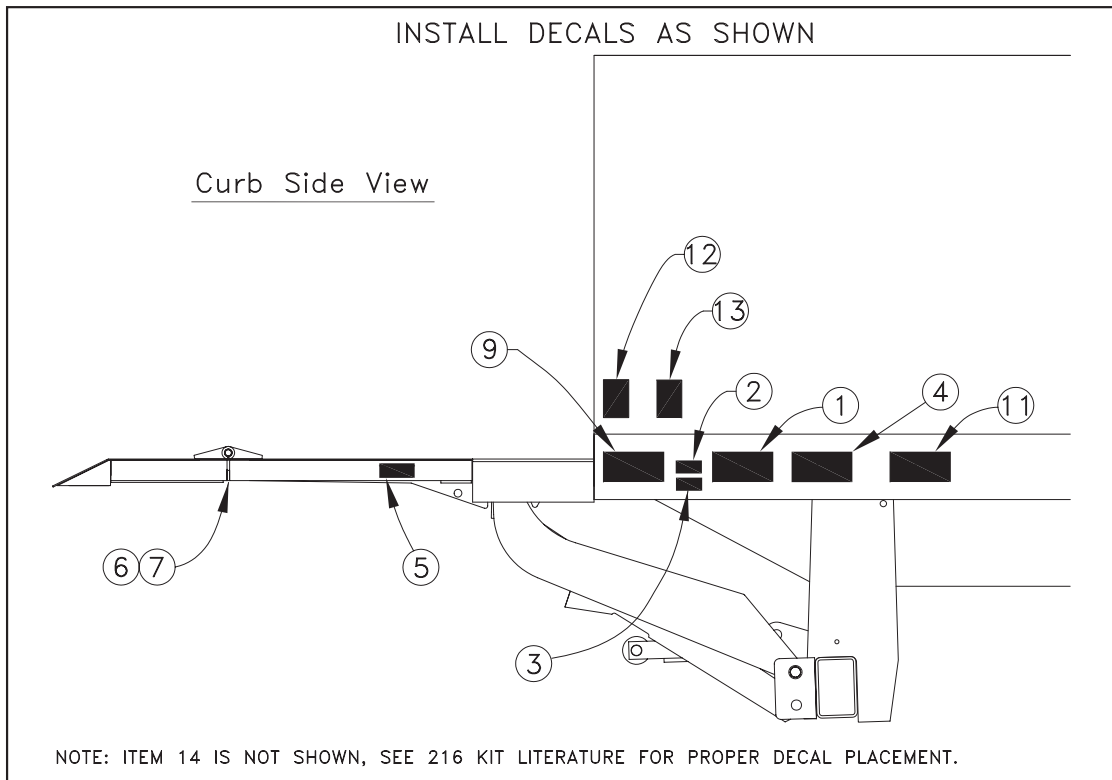

**PLATFORM ASSEMBLY - 32+5, 36+6, 42+6 (STEEL MAIN/EXT.)**

Item	Part Number	Description	Platform Size/Qty		
			32+5	36+6	42+6
1	31421-001	Platform Asm 7232	1		
1	31421-002	Platform Asm 8432	1		
1	31420-001	Platform Asm 7236		1	
1	31420-002	Platform Asm 8436		1	
1	3468-001	Platform Asm 7242			1
1	3468-002	Platform Asm 8442			1
2	31417-001	Main Section Weld 7232	1		
2	31417-002	Main Section Weld 8432	1		
2	31418-001	Main Section Weld 7236		1	
2	31418-002	Main Section Weld 8436		1	
2	31659-001	Main Section Weld 7242			1
2	31659-002	Main Section Weld 8442			1
3	31717-001	Extension Weld 7232	1		
3	31717-002	Extension Weld 8432	1		
3	31097-001	Extension Weld 7236		1	
3	31097-002	Extension Weld 8436		1	
3	31678-001	Extension Weld 7242			1
3	31678-002	Extension Weld 8442			1
4	3023-001	Support Tube	1	1	1
5	5101260	Spring	2	2	3
6	5050	Pin	1	1	1
7	8120378	Nut .50	1	1	1
8	9414074	Locknut .50	1	1	1
9	5781017	Retaining Ring	5	5	5
10	5051	Pin	1	1	1
11	5056	Pin	2	2	2
12	5711	Shoulder Eye Bolt	1	1	1
13	8107-011	Washer	2	2	2
14	5504-016	Bushing	4	4	4

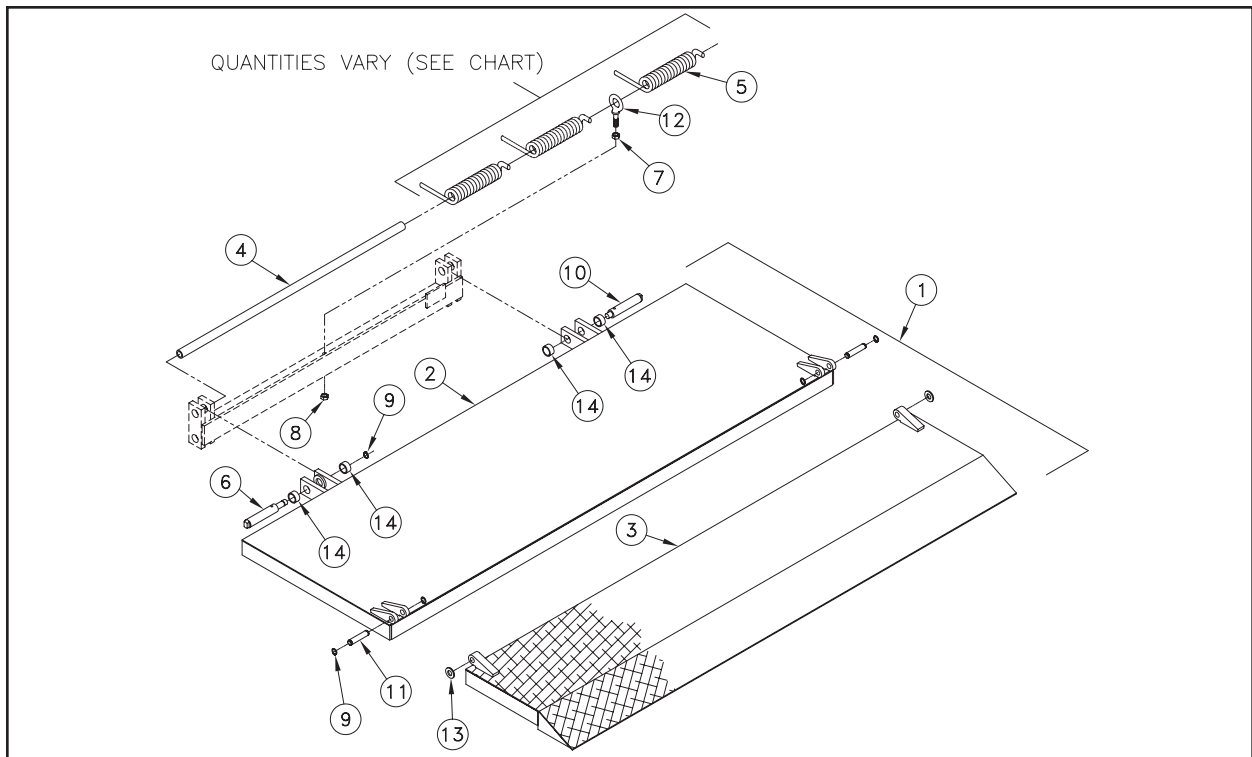

**PLATFORM ASSEMBLY - M25 OR MDC30, 42+10 RET. (STEEL MAIN/EXT.)**

Item	Part Number	Description	Gate Model/Qty.	
			M25	MDC
1	3465-001	Platform Asm 7242+10 - M25	1	
1	3465-002	Platform Asm 8442+10 - M25	1	
1	3467-001	Platform Asm 7242+10 - MDC30		1
1	3467-002	Platform Asm 8442+10 - MDC30		1
2	31418-001	Main Section Weld 7242+10 - M25	1	
2	31418-002	Main Section Weld 8442+10 - M25	1	
2	31677-001	Main Section Weld 7242+10 - MDC30		1
2	31677-002	Main Section Weld 8442+10 - MDC30		1
3	31654-001	Extension Weld 7242+10 - M25, MDC30	1	1
3	31654-002	Extension Weld 8442+10 - M25, MDC30	1	1
4	31655-001	Ramp Asm 7242+10 - M25, MDC30	1	1
4	31655-002	Ramp Asm 8442+10 - M25, MDC30	1	1
5	3023-001	Support Tube	1	1
6	5101260	Spring	2	3
7	5050	Pin	1	1
8	8120378	Nut .50	1	1
9	9414074	Locknut .50	1	1
10	5781017	Retaining Ring	9	9
11	5051	Pin	1	1
12	5056	Pin	4	4
13	5711	Shoulder Eye Bolt	1	1
14	8107-011	Washer .62	4	4
15	5504-016	Bushing	4	4
16	5708-001	Spring Pin	2	2
17	8109-008	.25 Set Screw	1	1
18	5746	Cable	2	2
19	8180126	Screw .38 x 1.50	2	2
20	9413534	Locknut .38	2	2
21	8180122	Screw .38 x 1.00	1	1
22	27215	Retainer	1	1

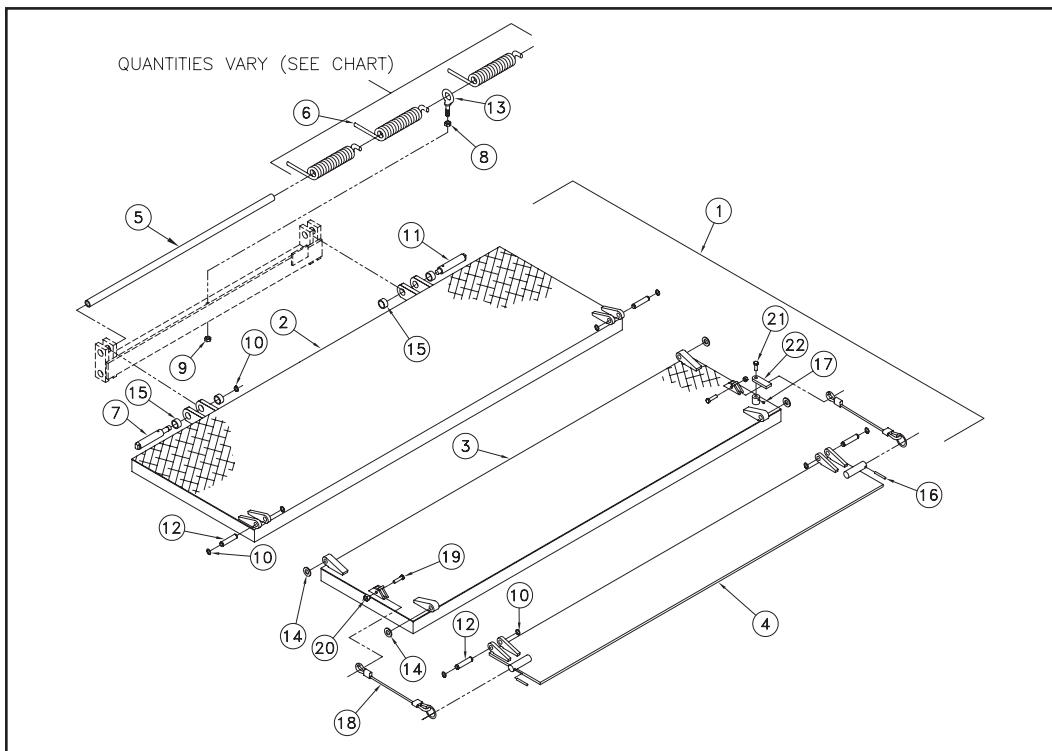

**PLATFORM ASSEMBLY - M OR MDC, 42W (STEEL MAIN/EXT.)**

Item	Part Number	Description	Gate Model/Qty.	
			M25	MDC
1	31426-001	Platform Asm 7242W-M	1	
1	31426-002	Platform Asm 8442W-M	1	
1	3466-001	Platform Asm 7242W-MDC		1
1	3466-002	Platform Asm 8442W-MDC		1
2	31418-001	Main Section Weld 7242W-M	1	
2	31418-002	Main Section Weld 8442W-M	1	
2	31677-001	Main Section Weld 7242W-MDC		1
2	31677-002	Main Section Weld 8442W-MDC		1
3	31155-001	Extension Weld 7242-M, MDC	1	1
3	31155-002	Extension Weld 8442-M, MDC	1	1
4	3023-001	Support Tube	1	1
5	5101260	Spring	2	2
6	5050	Pin	1	1
7	8120378	Nut .50	1	1
8	9414074	Locknut .50	1	1
9	5781017	Retaining Ring	5	5
10	5051	Pin	1	1
11	5056	Pin	2	2
12	5711	Shoulder Eye Bolt	1	1
13	8107-011	Washer .62	2	2
14	5504-016	Bushing	4	4

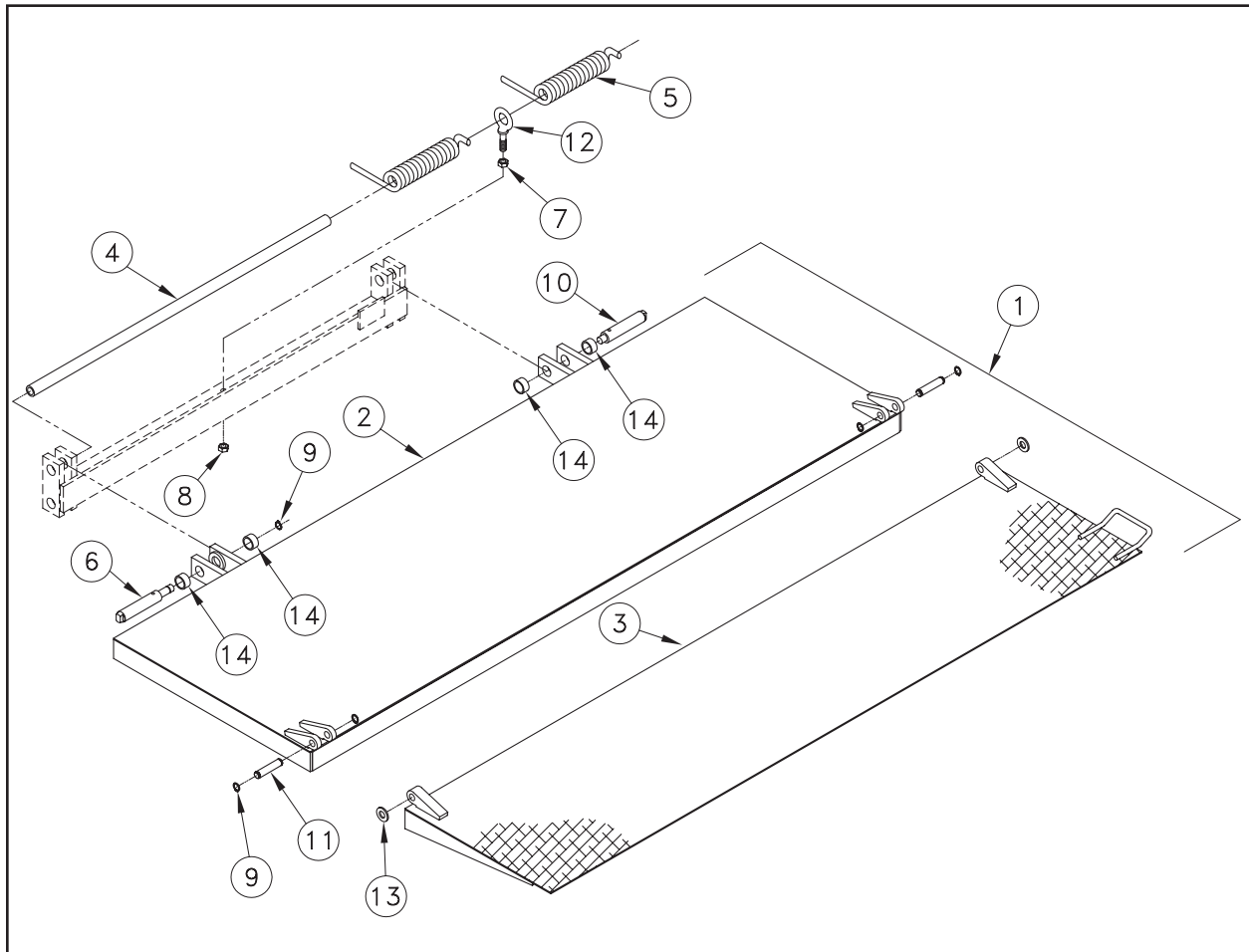

### PLATFORM ASSEMBLY - 48W (STEEL MAIN/ALUM. EXT.)

Item	Part Number	Description	Qty.
1	3469-001	Platform Asm 7248W	1
1	3469-002	Platform Asm 8448W	1
2	31680-001	Main Section Weld 7248W	1
2	31680-002	Main Section Weld 8448W	1
3	31682-001	Extension Weld 7248W AL	1
3	31682-002	Extension Weld 8448W AL	1
4	3023-001	Support Tube	1
5	5101260	Spring	2
6	5050	Pin	1
7	8120378	Nut .50	1
8	9414074	Locknut .50	3
9	5781017	Retaining Ring	1
10	5051	Pin	1
11	8119	Shoulder Screw .50	2
12	5711	Shoulder Eye Bolt	1
13	8107-011	Washer .62	2
14	5504-016	Bushing	4
15	8106-009	Lockwasher .63	2
16	8106-008	Lockwasher .50	2
17	5504-013	Bushing	2
18	8120377	Nut .38	1
19	21042	Latch	1
20	8120388	Washer .38	1
21	8180126	Screw .38 x 1.50	1

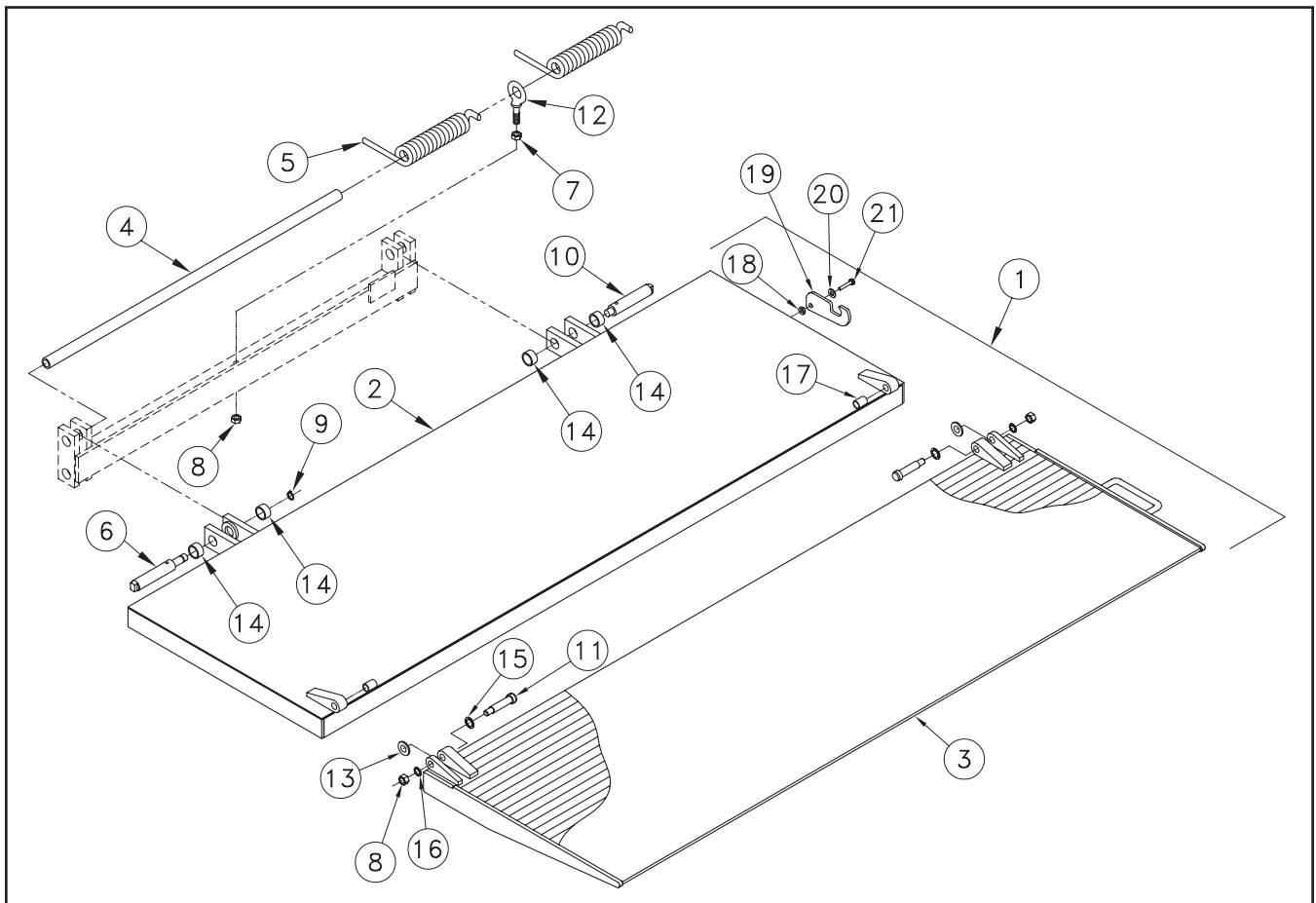



**PLATFORM ASSEMBLY - M30 36+6/MDC 40+6 (ALUM. MAIN/EXT.)**

Item	Part Number	Description	Qty.
1	3470-001	Platform Asm 7236	1
1	3470-002	Platform Asm 8436	1
1	31731-001	Platform Asm 7240	1
1	31731-002	Platform Asm 8440	1
2	31728-001	Main Section Weld 7236, 7240	1
2	31728-002	Main Section Weld 8436, 8440	1
3	31738-001	Extension Weld 7236	1
3	31738-002	Extension Weld 8436	1
3	31730-001	Extension Weld 7240	1
3	31730-002	Extension Weld 8440	1
4	3023-001	Support Tube	1
5	5101260	Spring	1
6	5050	Pin	1
7	8120378	Nut .50	1
8	9414074	Locknut .50	3
9	5781017	Retaining Ring	1
10	5051	Pin	1
11	8119	Shoulder Bolt .62	2
12	5711	Shoulder Eye Bolt	1
13	8107-011	Washer .62	2
14	5504-021	Bushing	2
15	5504-019	Bushing	2
16	8106-008	Lockwasher .50	2
17	8106-009	Lockwasher .62	2
18	5504-013	Bushing	2

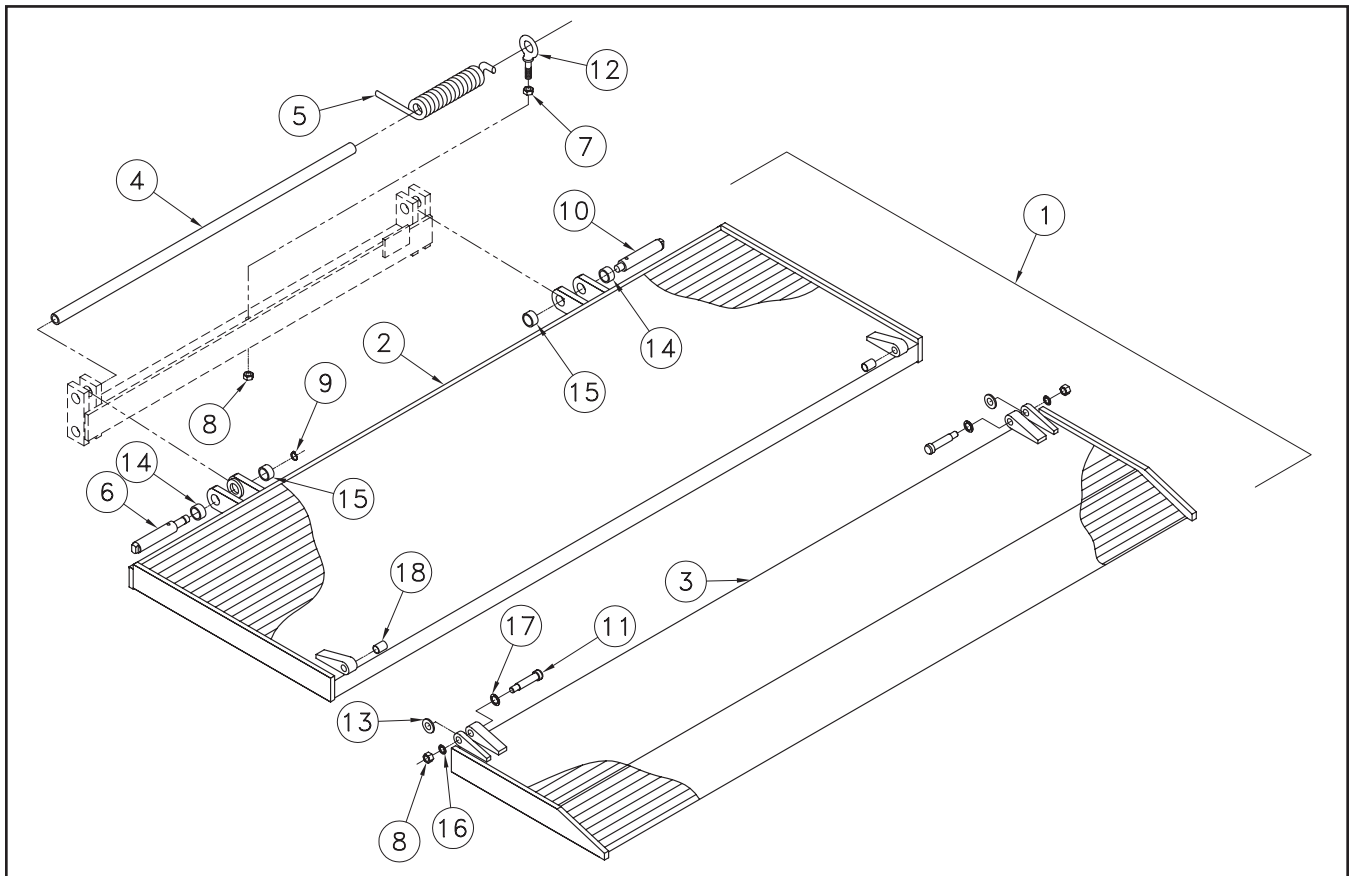

**PLATFORM ASSEMBLY - 42+10 RET. (ALUM. MAIN/EXT.)**

Item	Part Number	Description	Qty.
1	31734-001	Platform Asm 7242+10	1
1	31734-002	Platform Asm 8442+10	1
2	31728-001	Main Section Weld 7242+10	1
2	31728-002	Main Section Weld 8442+10	1
3	31732-001	Extension Weld 7242+10	1
3	31732-002	Extension Weld 8442+10	1
4	31735-001	Ramp Asm 7242+10	1
4	31735-002	Ramp Asm 8442+10	1
5	5101260	Spring	1
6	5050	Pin	1
7	8120378	Nut .50	1
8	9414074	Locknut .50	3
9	5781017	Retaining Ring	5
10	5051	Pin	1
11	8119	Shoulder Bolt .62	2
12	5711	Shoulder Eye Bolt	1
13	8107-011	Washer .62	4
14	5504-021	Bushing	2
15	5504-019	Bushing	2
16	8106-008	Lockwasher .50	2
17	8106-009	Lockwasher .62	2
18	5504-013	Bushing	2
19	5056	Pin	2
20	5746	Cable	2
21	8180126	Screw .38 x 1.50	1
22	27215	Retainer	1
23	8180122	Screw .38 x 1.00	1
24	8109-008	Set Screw .25	1
25	5708-001	Spring Pin	2
26	3023-001	Support Tube	1
27	9413534	Locknut .38	2

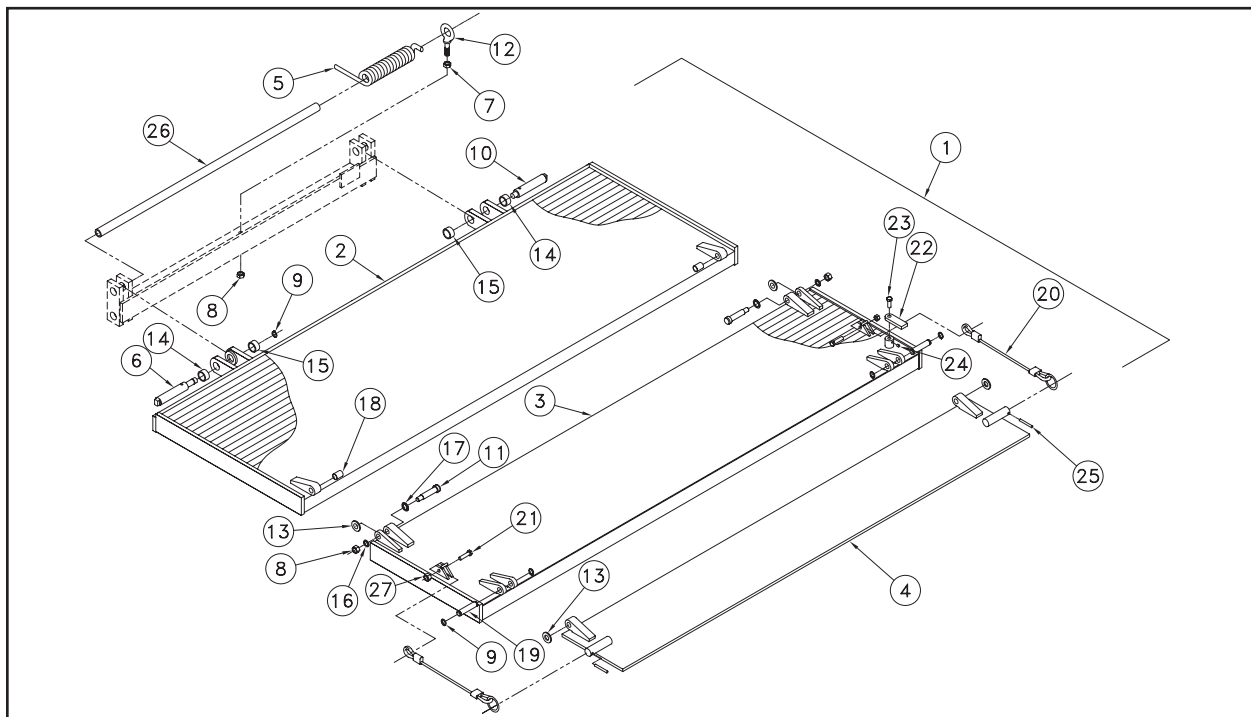

### PLATFORM ASSEMBLY - 48W (ALUM. MAIN/EXT.)

Item	Part Number	Description	Qty.
1	31729-001	Platform Asm 7248W	1
1	31729-002	Platform Asm 8448W	1
2	31728-001	Main Section Weld 7248W	1
2	31728-002	Main Section Weld 8448W	1
3	31682-001	Extension Weld 7248W	1
3	31682-002	Extension Weld 8448W	1
4	3023-001	Support Tube	1
5	5101260	Spring	1
6	5050	Pin	1
7	8120378	Nut .50	1
8	9414074	Locknut .50	3
9	5781017	Retaining Ring	1
10	5051	Pin	1
11	8119	Shoulder Bolt .62	2
12	5711	Shoulder Eye Bolt	1
13	8107-011	Washer .62	2
14	5504-021	Bushing	2
15	5504-019	Bushing	2
16	8106-008	Lockwasher .50	2
17	8106-009	Lockwasher .62	2
18	5504-013	Bushing	2
19	8107-001	Washer .38	1
20	21042	Latch	1
21	8103-002	Nut .38	1
22	8108-002	Screw .38 x 1.50	1

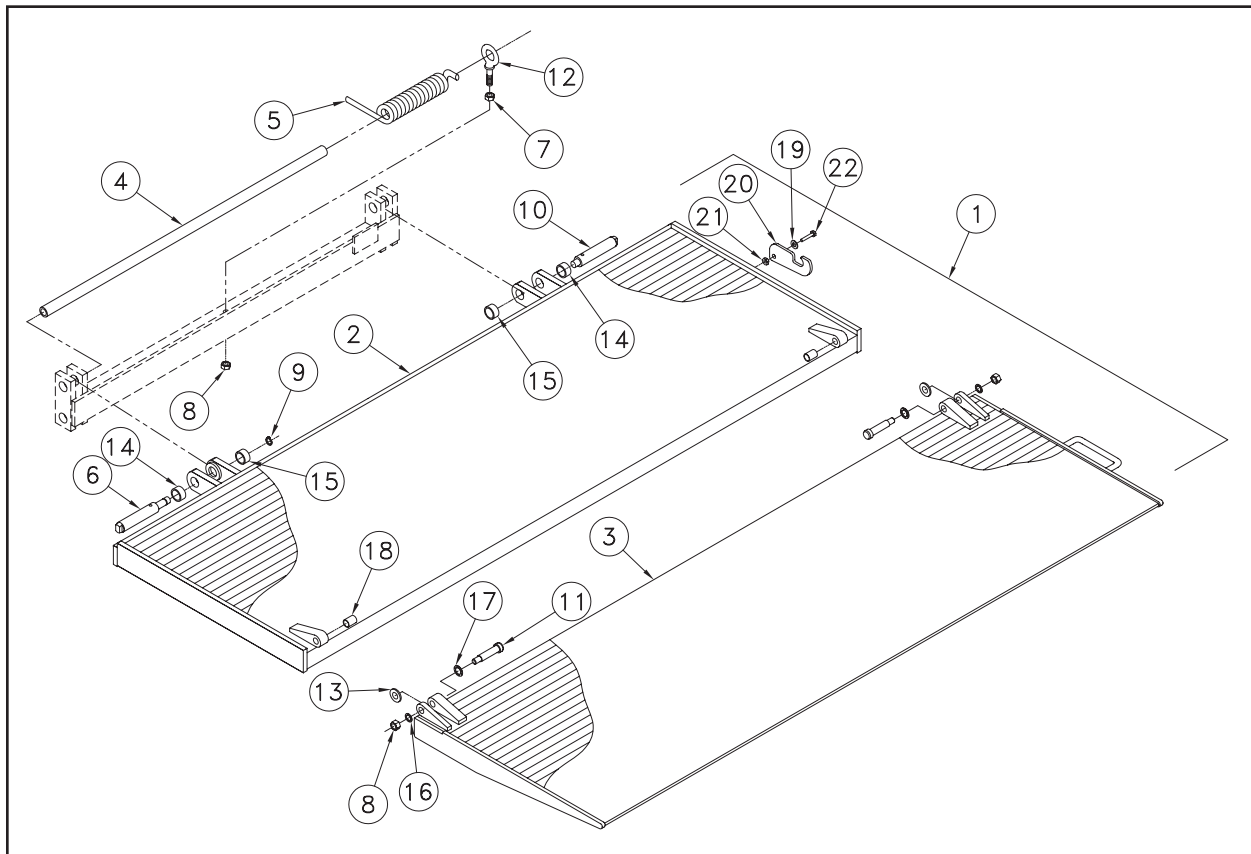

## SPACER ASSEMBLY

Item	Part Number	Description	Qty.
1	3500-001	Spacer Asm - 96"	1
1	3500-002	Spacer Asm - 102"	1
2	2404-002	Control Shaft - 96" Spacer Asm.	1
2	2404-003	Control Shaft - 102" Spacer Asm.	1
3	31592	Latch	1
4	5101100	Spring	1
5	5701043	Handle	1
6	23168-005	Flat Bar	1

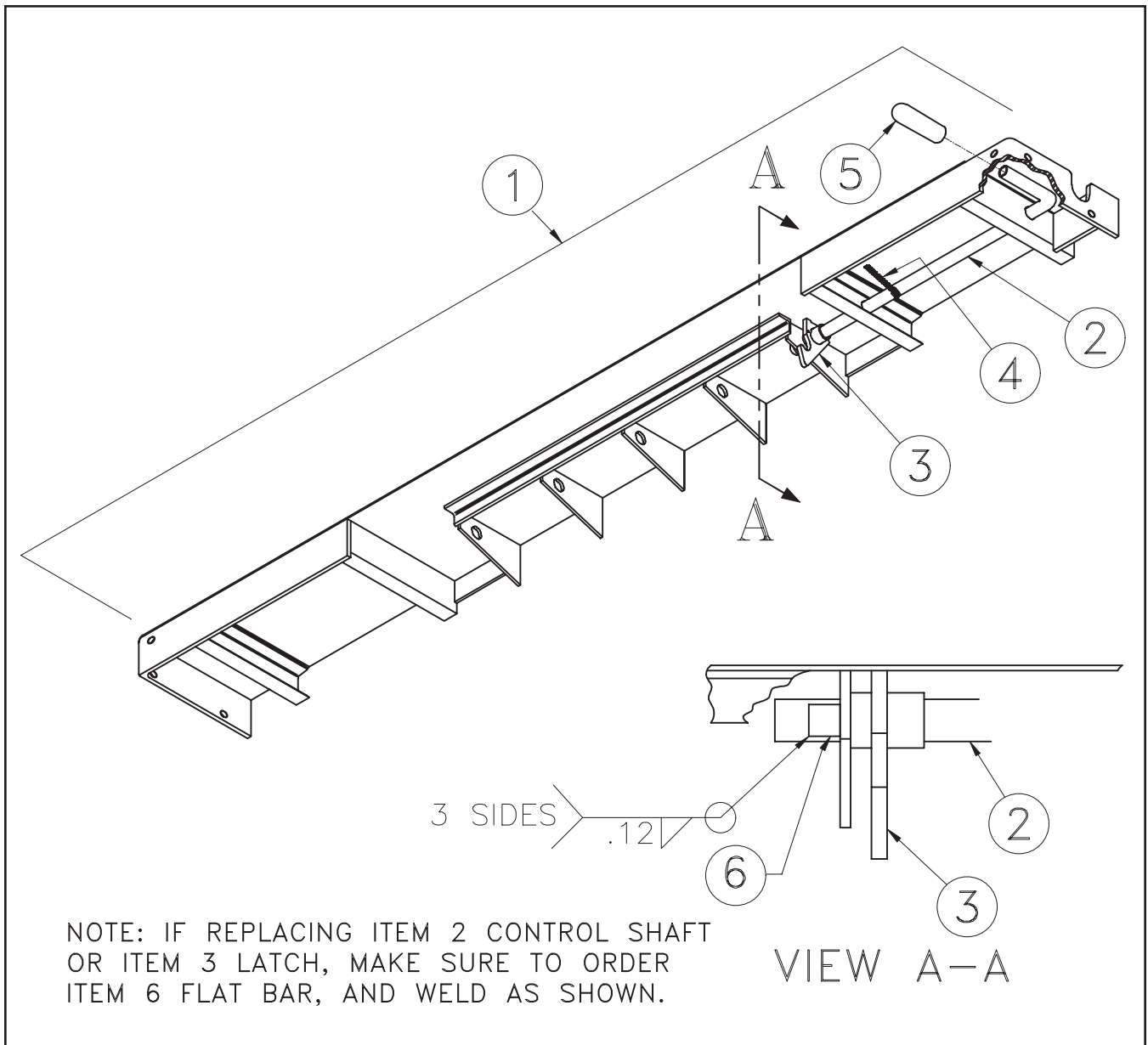

## TRUNNION, LIFT ARM, & IDLER ARMS - M25/30

Item	Part Number	Description	Platform Size/Qty			
			32+5	36+6	42+10	42W
1	31412-001	Trunnion Weld - M		1	1	1
1	31412-002	Trunnion Weld - MLB	1			
1	31412-003	Trunnion Weld - Pintle		1	1	1
2	21030	Mounting Plate	1	1	1	1
3A	31413	Idler Arm	2	2		2
3B	31736-001	Idler Arm - L.H.			1	
3C	31736-002	Idler Arm - R.H.			1	
4	31414	Lift Arm Weld	1	1	1	1
5	31416	Pivot Bar Weld-4.13		1	1	
5	31427	Pivot Bar Weld-4.25	1			1
6	5701330	Roller	1	1	1	1
7	5031	Pin	1	1	1	1
8	5781008	Retaining Ring	2	2	2	2
9	8271291	Zerk	1	1	1	1
10	5047	Pin	4	4	4	4
11	5702371	Spring	4	4	4	4
12	5075	Pin	2	2	2	2
13	5504-005	Bushing	2	2	2	2
14	5708-001	Spring Pin	4	4	4	4
15	5504-017	Bushing	2	2	2	2
16	5504-016	Bushing	6	6	6	6
17	5789	Wear Pad			2	
18	5793010	Self-Tapping Screw - .25-20			4	

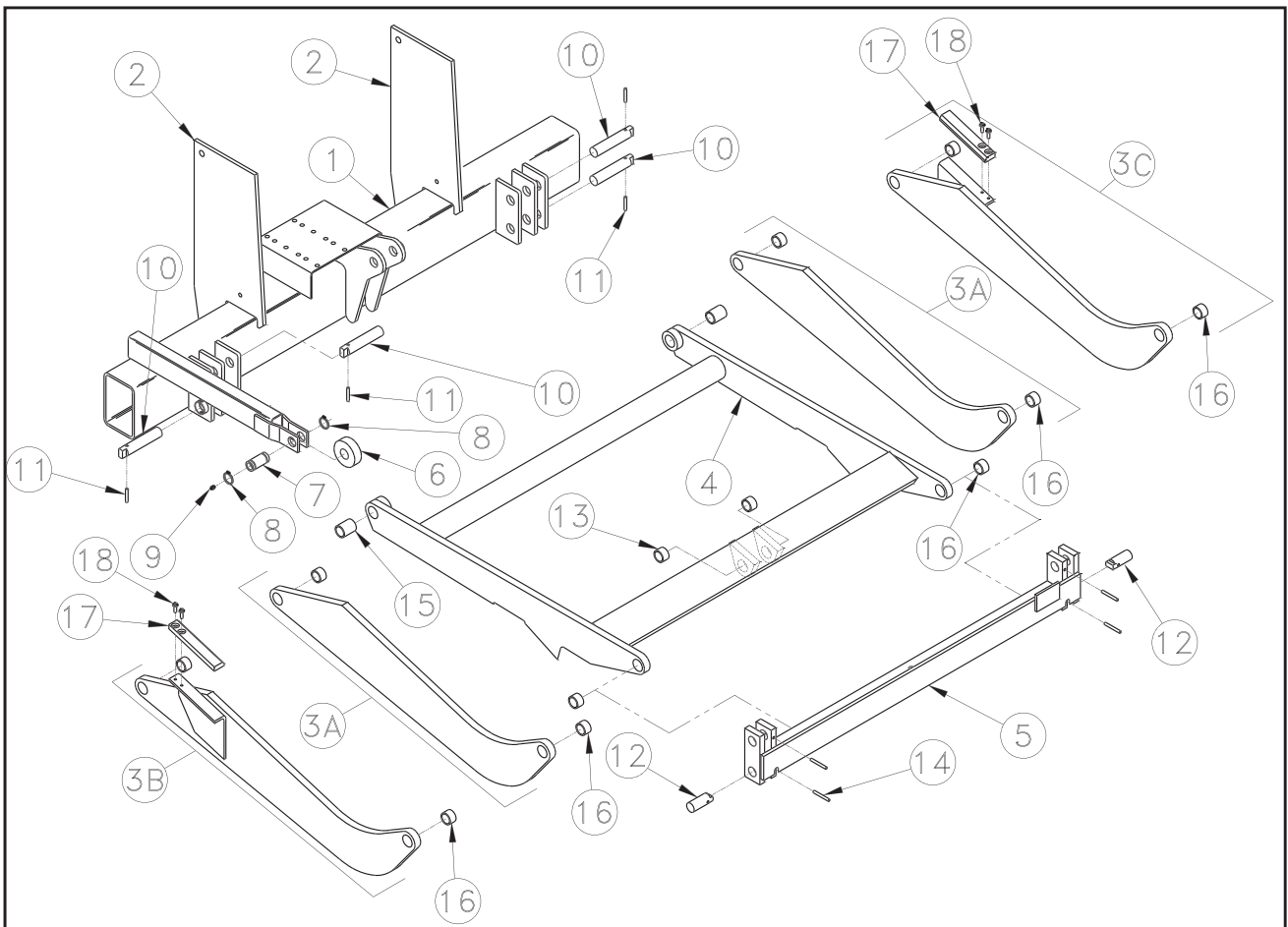

## TRUNNION, LIFT ARM, AND IDLER ARMS - MDC25/30

Item	Part Number	Description	Platform Size Qty.							
			42+6, 40+6 AL	42W	42+10 RET		48W	48W-LB	48W AL	48W AL-LB
					ST	AL				
1	31676-001	Trunnion Weld	1	1	1	1	1	1	1	1
1	31676-003	Trunnion Weld-Pintle	1	1	1	1	1	1	1	1
2	21030	Mounting Plate	1	1	1	1	1	1	1	1
3A	31413	Idler Arm	2	2						
3B	31674-001	Idler Arm - L.H.			1					
3C	31674-002	Idler Arm - R.H.			1					
3D	31736-001	Idler Arm - L.H.				1				
3E	31736-002	Idler Arm - R.H.				1				
3F	31683-001	Idler Arm - L.H.					1	1	1	1
3G	31683-002	Idler Arm - R.H.					1	1	1	1
4	31675	Lift Arm	1	1	1	1	1	1	1	1
5	31679	Pivot Bar Weld-4.00	1							
5	31427	Pivot Bar Weld-4.25		1						
5	31416	Pivot Bar Weld-4.13			1	1				
5	31681	Pivot Bar Weld-4.19					1		1	
5	31737	Pivot Bar Weld-4.38						1		1
6	5701330	Roller	1	1	1	1	1	1	1	1
7	5031	Pin	1	1	1	1	1	1	1	1
8	5781008	Retaining Ring	2	2	2	2	2	2	2	2
9	8271291	Zerk	1	1	1	1	1	1	1	1
10	5047	Pin	4	4	4	4	4	4	4	4
11	5702371	Spring Pin	4	4	4	4	4	4	4	4
12	5075	Pin	2	2	2	2	2	2	2	2
13	5504-005	Bushing	4	4	4	4	4	4	4	4
14	5708-001	Spring Pin	4	4	4	4	4	4	4	4
15	5504-017	Bushing	2	2	2	2	2	2	2	2
16	5504-016	Bushing	6	6	6	6	6	6	6	6
17	5789	Wear Pad			2	2	2	2	2	2
18	5793010	Self Tap Screw-.25-20			4	4	4	4	4	4
19	8130999	Washer .69					6	6		
20	5702290	Rubber Bumper					2	2	2	2
21	9413447	Locknut .31					2	2	2	2
22	8120386	Washer .25					4	4	4	4
23	8180091	Screw .31 x 2.25					2	2	2	2

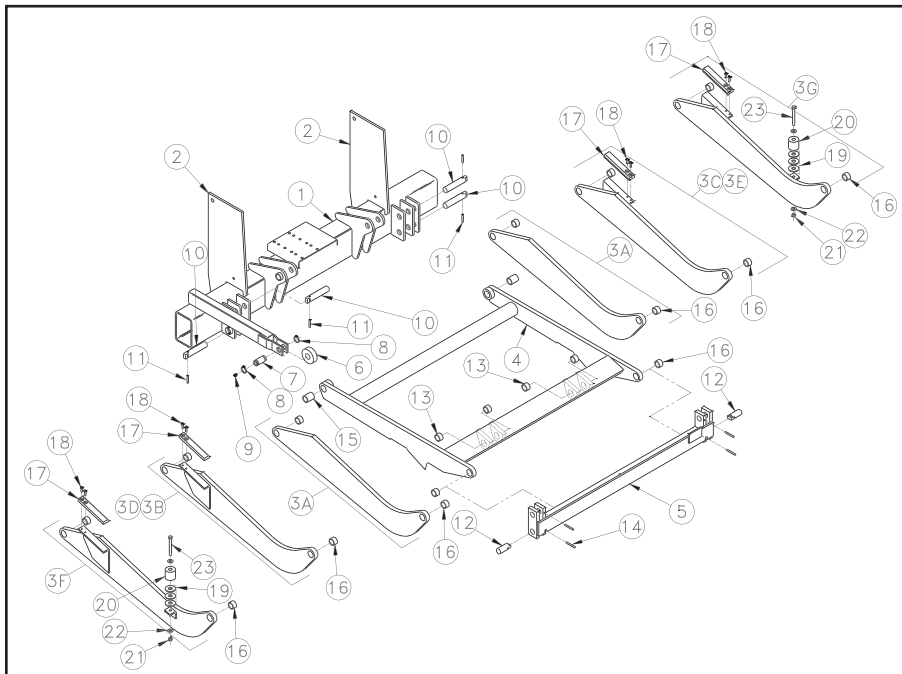

# ELECTRICAL PICTORIALS

## ELECTRIC CONTROL GRAVITY DOWN

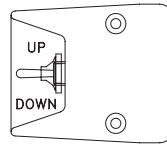
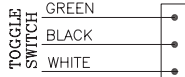
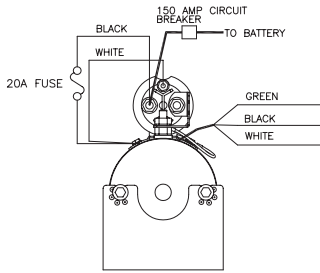

BACK SIDE OF PUSHBUTTON BOX

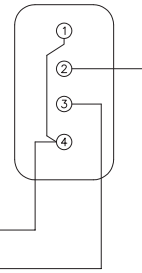

CONTROL SIDE OF PUSHBUTTON BOX

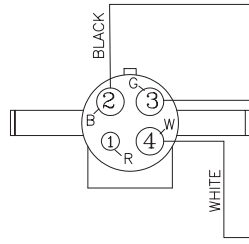
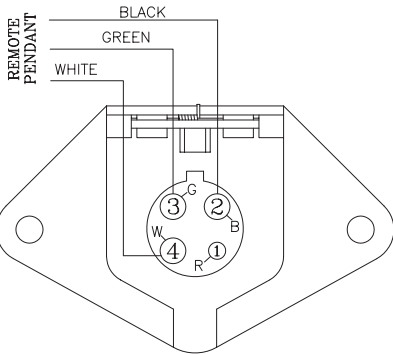
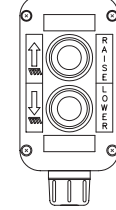

BACK SIDE OF PENDANT

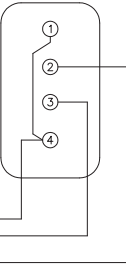

CONTROL SIDE OF PENDANT

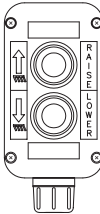

## POWER DOWN ELECTRIC CONTROL (TOGGLE, PUSHBUTTON, OR REMOTE PENDANT)

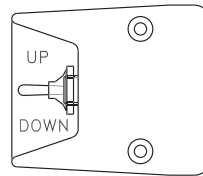
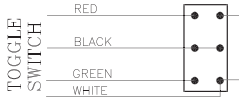
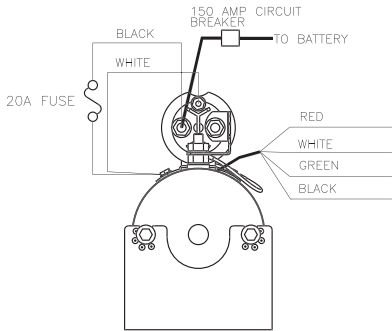

BACK SIDE OF PUSHBUTTON BOX

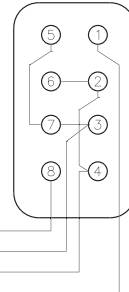

CONTROL SIDE OF PUSHBUTTON BOX

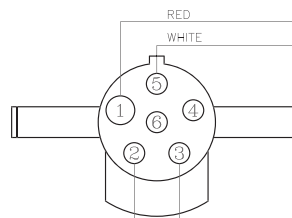
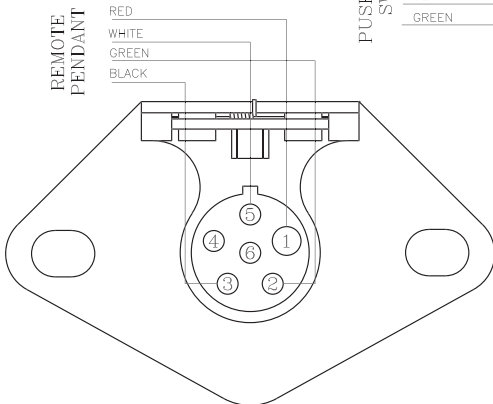
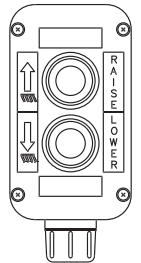

BACK SIDE OF PENDANT

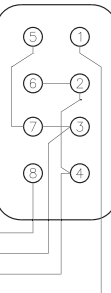

CONTROL SIDE OF PENDANT



## M25/30 PUMP ASSEMBLY - POWER DOWN

Item	Part Number	Description	Qty
1	4404	Pump Asm-Items 2 to 6	1
2	4421420	Pump Bracket	1
3	4421350	Mounting Bracket	1
4	4423520	Motor 8111	1
5	4468	Solenoid Start Switch	1
6	4420410	Breather Cap	1
7	5704	Cover	1
8	5700100	Strap	1
9	4930-001	MF-MAORB 90°	3
10	4948-001	Flow Control - 1.5 GPM	1
11	4936-001	MAORB-MAORB 90°	1
12	5053	Pin	1
13	4298	Cylinder Asm	1
14	4300030	Battery Cable #2 X 25'	1
15	4350	Cable Lug	1
16	8180126	Screw .38 x 1.50	5
17	8106-010	Internal Tooth Lockwasher .38	10
18	8120377	Nut .38	5
19	8120388	Flatwasher .38	4
20	31445	Toggle Switch ASM	1
21	5504-001	Bushing	2
22	4422860	Pushbutton Control-Optional	1
23	8111-005	Screw #10 x .75	2
24	4318-002	Ground Cable #2 x 2'	1
25	8104-006	Screw .31 x 1.00	1
26	5702371	Spring Pin	1
27	5059	Pin	1
28	5781008	Retaining Ring	2
29	4951-012	Hose 38"	2
30	4301770	Circuit Breaker 150 Amp	1
31	4318-001	Battery Cable #2 x 2'	1
32	4319-002	Shrink Wrap	1
33	4941-001	MJ-MORB Straight	1

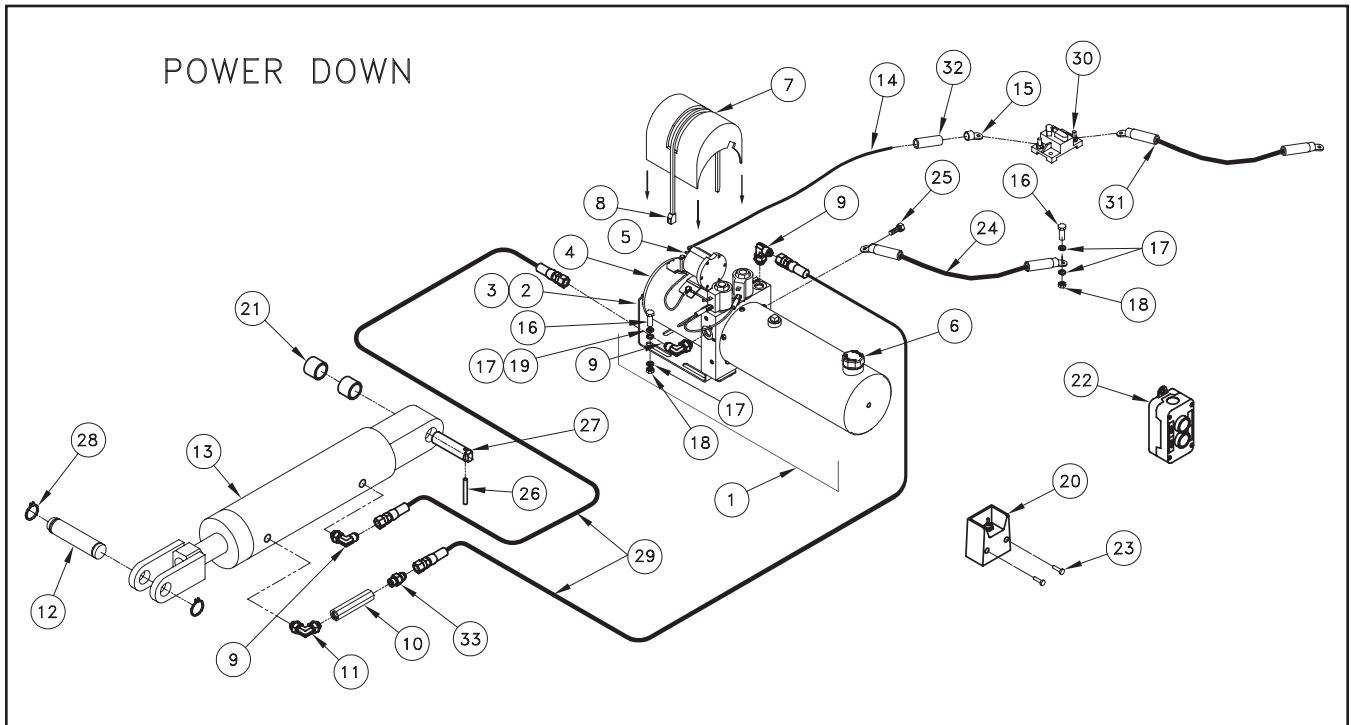

## M25/30 PUMP ASSEMBLY - GRAVITY DOWN

Item	Part Number	Description	Qty
1	4400351	Pump Asm-Items 2 to 6	1
2	4421420	Pump Bracket	1
3	4421350	Mounting Bracket	1
4	4423520	Motor 8111	1
5	4468	Solenoid Start Switch	1
6	4420410	Breather Cap	1
7	5704	Cover	1
8	5700100	Strap	1
9	4930-001	MJ-MAORB 90°	1
10	4951-012	Hose 38"	1
11	4948-001	Flow Control 1.5 GPM	1
12	4936-001	MAORB-MAORB 90°	1
13	5053	Pin	1
14	4298	Cylinder Asm	1
15	4300030	Battery Cable #2 x 25'	1
16	4350	Cable Lug	1
17	8180126	Screw .38 x 1.50	5
18	8106-010	Internal Tooth Lockwasher .38	10
19	8120377	Nut .38	5
20	8120388	Flatwasher .38	4
21	4933-001	Tube Elbow-BT-MAORB	2
22	31446	Toggle Switch ASM	1
23	5504-001	Bushing	2
24	8111-005	Screw #10 x .75	2
25	4422850	Pushbutton Control - Optional	1
26	4318-002	Ground Cable #2 x 2'	1
27	8104-006	Screw .31 x 1	1
28	5059	Pin	1
29	5702371	Spring Pin	1
30	5781008	Retaining Ring	2
31	4301770	Circuit Breaker 150 AMP	1
32	4318-001	Battery Cable #2 x 2'	1
33	4319-002	Shrink Wrap	1
34	4941-001	MJ-MAORB Straight	1
35	4921-005	Tubing 30.00	1

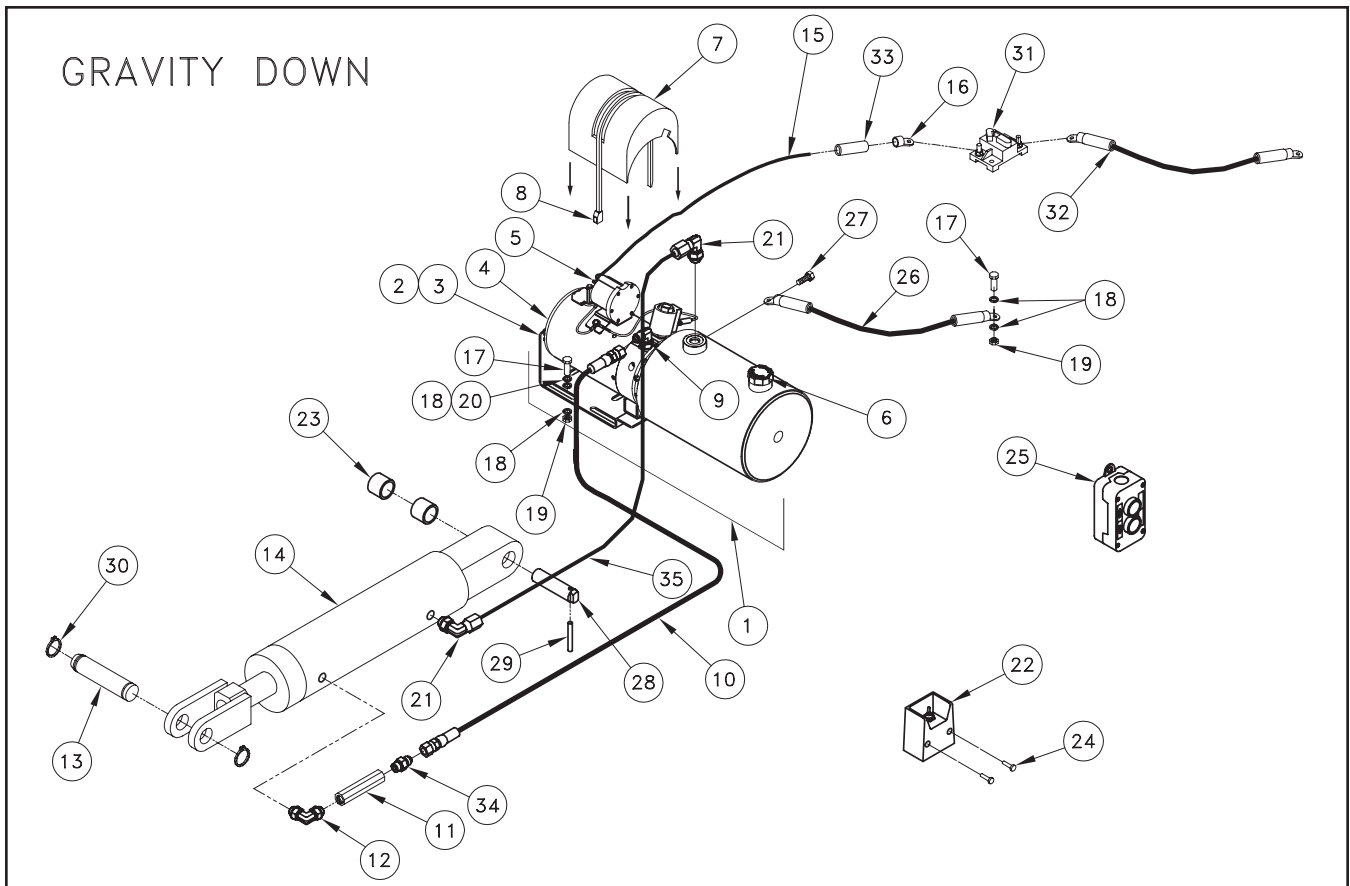

## MDC25/30 PUMP ASSEMBLY - POWER DOWN

Item	Part Number	Description	Qty
1	4499	Pump Asm-Items 2 to 6	1
2	4421420	Pump Bracket	1
3	4421350	Mounting Bracket	1
4	4423520	Motor 8111	1
5	4468	Solenoid Start Switch	1
6	4420410	Breather Cap	1
7	5704	Cover	1
8	5700100	Strap	1
9	4930-001	MJ-MAORB 90°	2
10	4948-001	Flow Control 1.5 GPM	2
11	4936-001	MAORB-MAORB 90°	2
12	5053	Pin	2
13	4299	Cylinder Asm	2
14	4300030	Battery Cable #2 x 25'	1
15	4350	Cable Lug	1
16	8180126	Screw .38 x 1.50	5
17	8106-010	Internal Tooth Lockwasher .38	10
18	8120377	Nut .38	5
19	8120388	Flatwasher .38	4
20	31445	Toggle Switch ASM	1
21	5504-001	Bushing	4
22	4422860	Pushbutton Control - Optional	1
23	8111-005	Screw #10 x .75	2
24	4318-002	Ground Cable #2 x 2'	1
25	8104-006	Screw .31 x 1	1
26	5702371	Spring Pin	2
27	5059	Pin	2
28	5781008	Retaining Ring	4
29	4951-012	Hose 38"	4
30	4301770	Circuite Breaker 150 AMP	1
31	4318-001	Battery Cable #2 x 2'	1
32	4319-002	Shrink Wrap	1
33	4941-001	MJ-MAORB Straight	2
34	4938-001	45° Elbow MAORB-FJS	1
35	4932-001	Branch Tee-MJ-MJ-MAORB	1
36	4953-001	Branch Tee-MJ-MJ-MJ	1

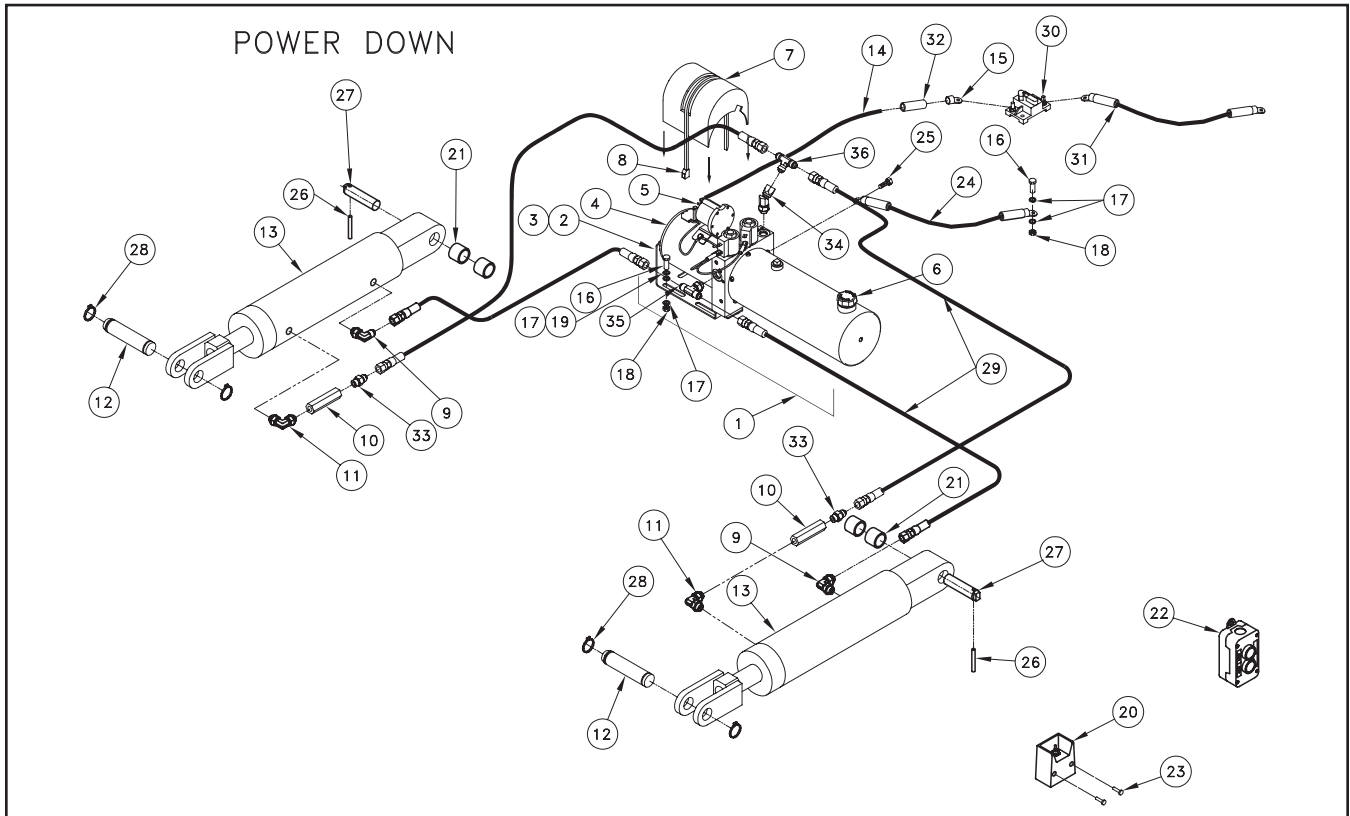

## MDC25/30 PUMP ASSEMBLY - GRAVITY DOWN

Item	Part Number	Description	Qty
1	4498	Pump Asm-Items 2 to 6	1
2	4421420	Pump Bracket	1
3	4421350	Mounting Bracket	1
4	4423520	Motor 8111	1
5	4468	Solenoid Start Switch	1
6	4420410	Breather Cap	1
7	5704	Cover	1
8	5700100	Strap	1
9	4932-001	Branch Tee MJ-MJ-MAORB	1
10	4951-012	Hose 38"	2
11	4948-001	Flow Control - 1.5 GPM	2
12	4936-001	MAORB-MAORB 90°	2
13	5053	Pin	2
14	4299	Cylinder Asm	2
15	4300030	Battery Cable #2 x 25'	1
16	4350	Cable Lug	1
17	8180126	Screw .38 x 1.50	5
18	8106-010	Internal Tooth Lockwasher .38	10
19	8120377	Nut .38	5
20	8120388	Flatwasher .38	4
21	4933-001	Tube Elbow-BT-MAORB	2
22	31446	Toggle Switch Asm	1
23	5504-001	Bushing	4
24	8111-005	Screw #10 x .75	2
25	4422850	Pushbutton Control - Optional	1
26	4318-002	Ground Cable #2 x 2'	1
27	8104-006	Screw .31 x 1	1
28	5059	Pin	2
29	5702371	Spring Pin	2
30	5781008	Retaining Ring	4
31	4301770	Circuit Breaker 150 Amp	1
32	4318-001	Battery #2 x 2'	1
33	4319-002	Shrink Wrap	1
34	4941-001	MJ-MAORB Straight	2
35	4968-001	Tube Tee-BT-BT-MAORB	1
36	4921-005	Tubing 30.00	2
37	4938-001	45° Elbow MAORB-FJ5	1

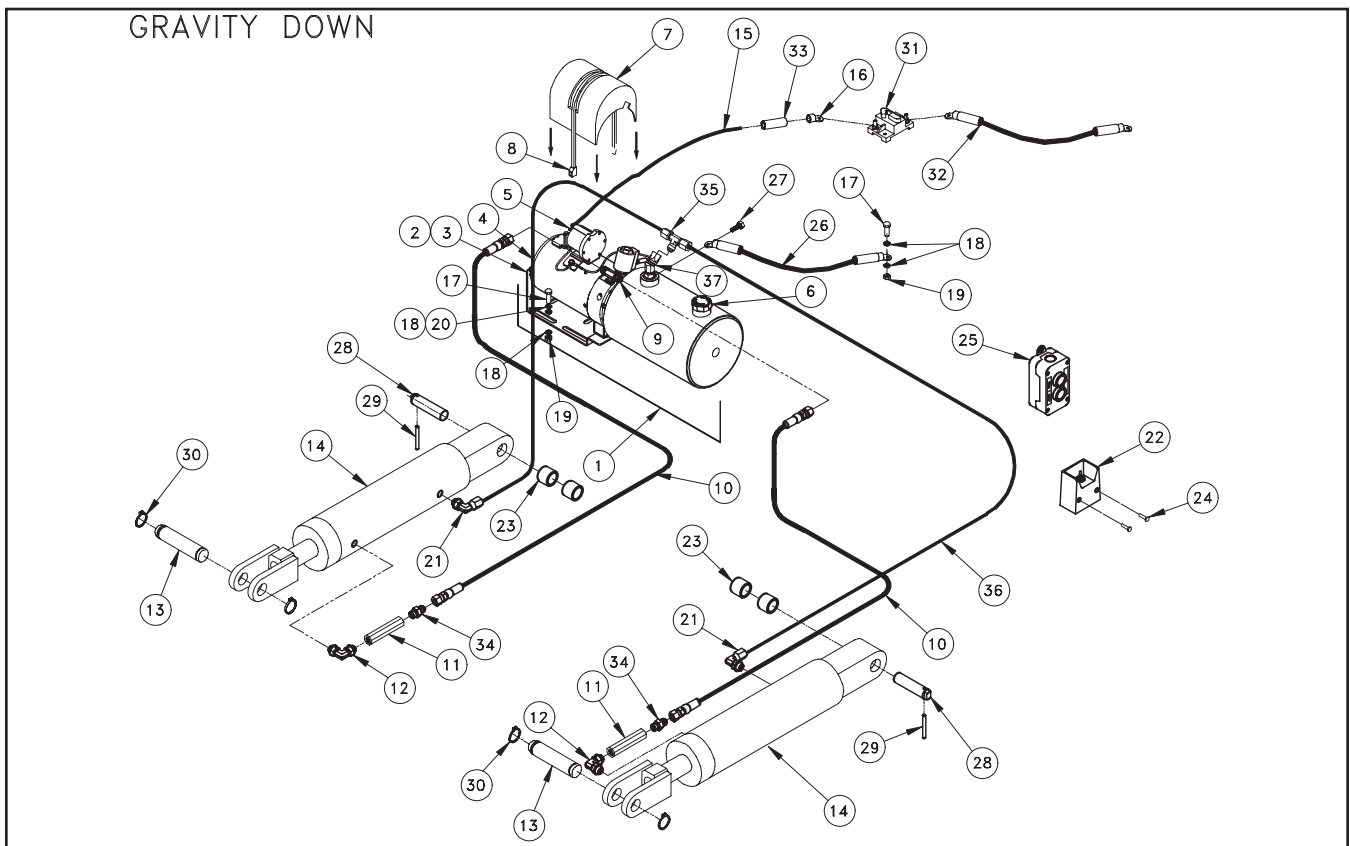

**4404 PUMP ASSEMBLY (2650 PSI)  
4499 PUMP ASSEMBLY (2000 PSI)**

Item	Part Number	Description	Qty./Model
1	4423520	Motor 8111	1
2	4439	Pump and Reservoir Asm (2650 PSI)	1
2	44009	Pump and Reservoir Asm (2000 PSI)	1
3	4420410	Breather Cap	1
4	4480	Buss Bar	1
5	4421520	Bearing	1
6	4421530	Seal	1
7	8109-012	Screw .25 x .75	2
8	4421420	Bracket	1
9	4468	Solenoid	1
10	4421600	O-Ring	2
11	4452	Solenoid Coil only	2
12	4445	Solenoid Valve Asm (lower)	1
13	4438	Solenoid Valve Asm (raise)	1
14	4457	Reservoir - Ø4.5 x 12.00	1
15	4421660	Self Tap Screw #10 x .38	6

# 4404/4499 POWER DOWN

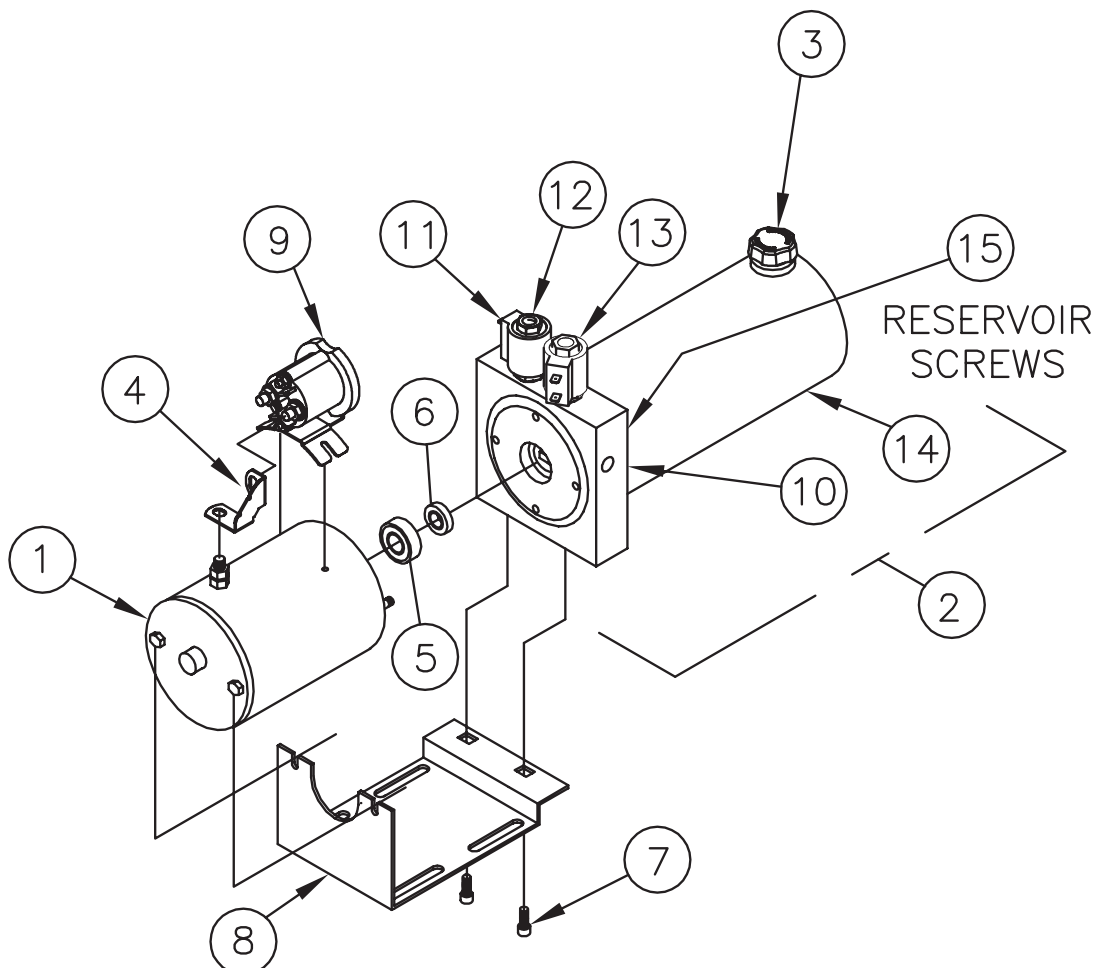

**4400351 PUMP ASSEMBLY (2500 PSI)  
4498 PUMP ASSEMBLY (2000 PSI)**

Item	Part Number	Description	Qty./Model
1	4423520	Motor 8111	1
2	4400359	Pump and Reservoir Only (2500 PSI)	1
2	44008	Pump and Reservoir Only (2000 PSI)	1
3	4420410	Breather Cap	1
4	4403	Reservoir Ø6 x 9	1
5	4421520	Bearing	1
6	4421530	Seal	1
7	4421350	Bracket	1
8	4421420	Bracket	1
9	4480	Buss Bar	1
10	4468	Solenoid	1
11	4421600	O-Ring	1
12	8109-009	Screw .25 x 1.38	2
13	4445	Valve Asm	1
14	4452	Coil only	1
15	4421660	Self Tap Screw #10 x .38	6

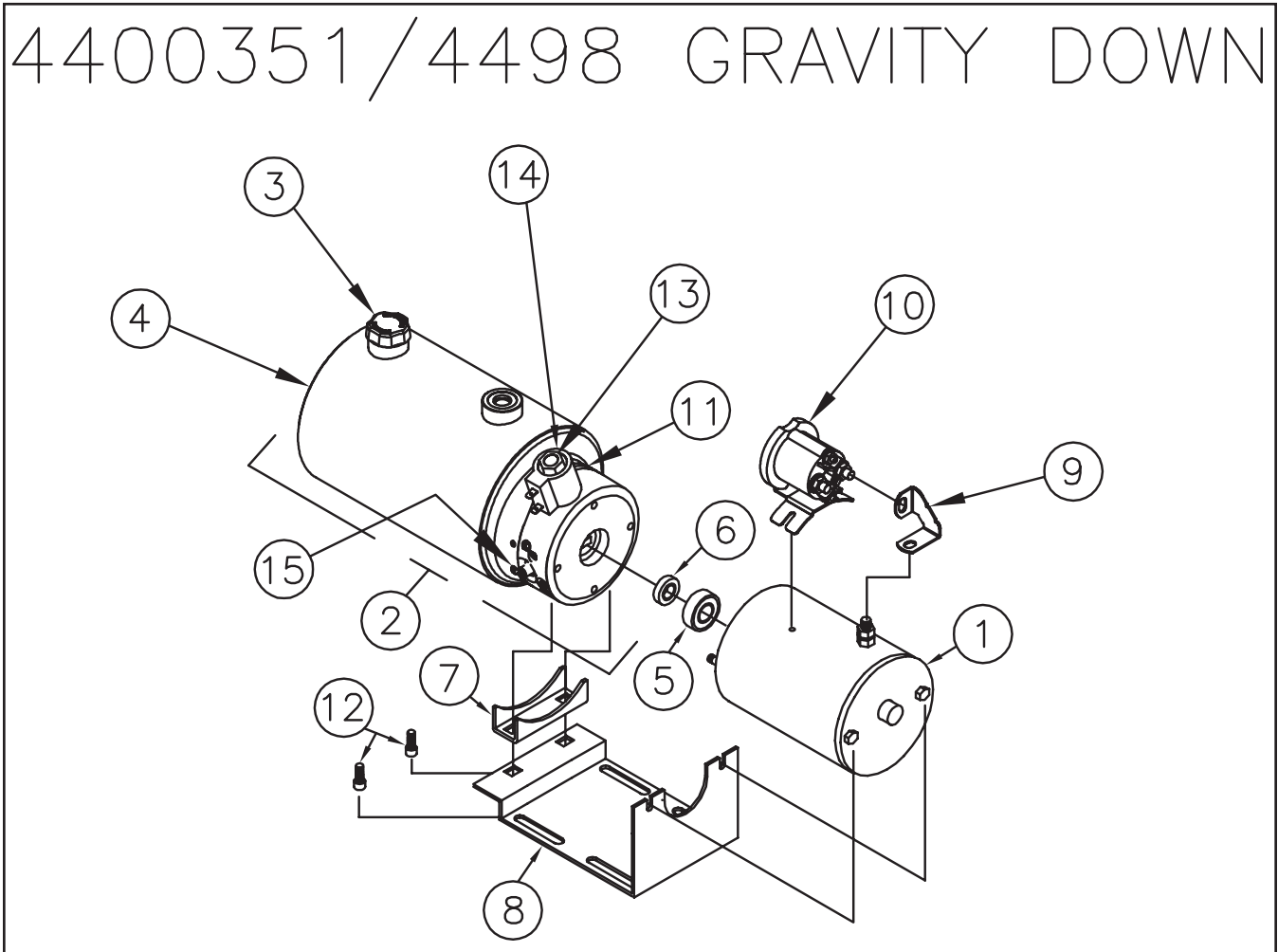

Snubber Kit 172			
Item	Part Description	Part Number	Qty.
	Snubber Kit Items 1 to 6	3735330	1
1	Snubber	5702290	2
2	Mounting Angle	2019033	2
3	Locknut .31-18	9413447	2
4	Flat Washer .31	8120386	4
5	Base Plate	23049-001	2
6	Screw .31-18	8180091	2

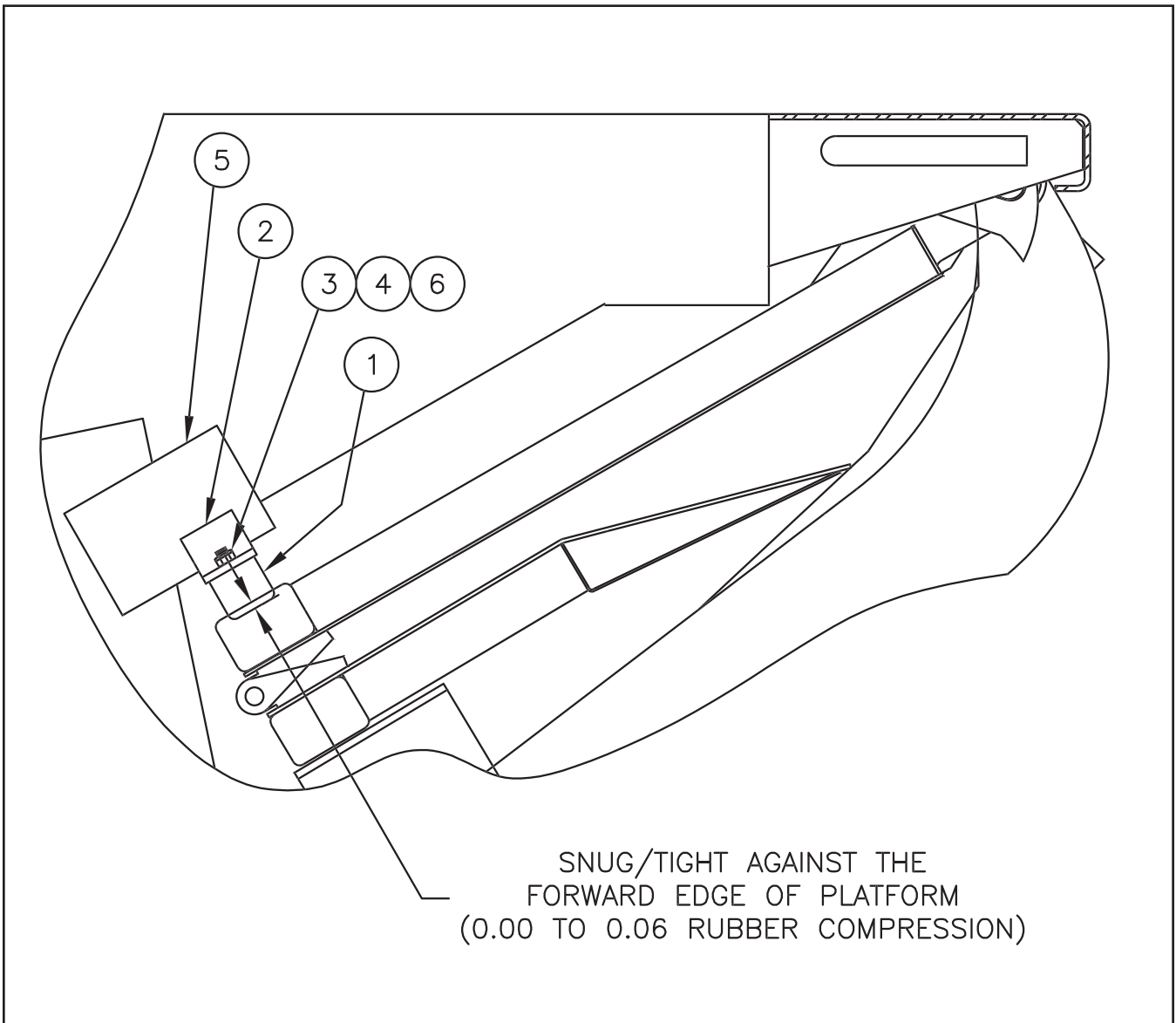

**TROUBLESHOOTING GUIDE**  
**M25/30 ET**

- Test Equipment:**
1. 0-5000 psi pressure gauge
  2. DC voltmeter/ohm meter
  3. DC amp meter
  4. standard mechanics tools

Note: Please refer to the electrical diagrams and hose connection drawings in the liftgate's owners manual when troubleshooting. This guide is only for standard Thieman liftgates. Special liftgates with options other than those in the owner's manual will require special diagrams for troubleshooting. Read and understand this entire guide completely before doing any troubleshooting. Certain listed problems may be related to other problems listed so a comprehensive knowledge is required before proceeding.

<b>1. Problem - Pump motor will not run in the raise mode</b>	
<b>Cause</b>	<b>Correction</b>
a. Tripped circuit breaker	Reset the circuit breaker located within 2ft of the liftgate supply battery(ies).
b. Blown 20A fuse	Replace 20A fuse (s). Each control cord should have a 20A in-line fuse on the black wire, where it connects to the 2ga. battery cable at the motor start solenoid.
c. Improper battery cable connection or improper ground connection	The "at rest" voltage for the batteries without the engine running and under no load should be at least 12.5V, and this voltage should be seen on the heavy 2ga. battery cable, where it connects to the large terminal of the motor start solenoid. The minimum voltage between the motor stud and ground is 10V at maximum conditions, with pump motor, batteries, and cables under max. load. If the voltage is dropping below 10V under max. load, bad connections may be acting like resistors and causing larger voltage drops than expected. Check voltage drops with system under load at different locations between the liftgate and battery source, to locate bad connections along the battery cable. Trace ground cable connections also to locate improper connection(s) along the ground path. Make sure the ground cable is installed going from the 5/16 tapped hole in the aluminum pump base marked GND to the liftgate mounting plate (scrape paint to bare metal for good ground). The ground cable from the batteries to the frame must be a heavy 2ga. cable that is connected to bare metal on the frame. Replace any damaged cables and repair any bad connections
d. Defective or undercharged battery(ies)	If proper voltage is not present, load test batteries and replace any defective batteries. The battery(ies) on the vehicle should be that which has a minimum 180 amp reserve capacity.
e. Defective or improperly wired raise switch	Check voltage on the black wire of the control cord near the switch. If no voltage is present the black wire from the motor start solenoid is loose or broken and needs repaired. If voltage is present then check for voltage at the white wire on the switch with the switch in the "UP" position. If no voltage is present, replace the switch.
f. Defective or improperly wired solenoid start switch	Check for voltage on the white wire at the motor start solenoid when the switch is activated "UP". If no voltage exists the white wire is loose or broken between the switch and the motor start solenoid. Check that the purple ground wire on the start solenoid is connected properly and there are no bad connections. If there is voltage on the white wire and the coil does not energize or if there is no voltage on the motor side of the solenoid or a large voltage drop present across the large terminals of the motor start solenoid then replace the motor start solenoid.
g. Defective pump motor	With the switch activated in the "UP" position and the motor start solenoid activated, check for voltage (10V minimum) at the motor terminal. If proper voltage is present and the motor is not running, double check the motor ground (see correction c. above.). If the motor has proper voltage and good ground and does not run, replace the motor.

2. Problem - Liftgate will not raise or raises slowly with a load and the pump motor running. The raise speed of the M25/30 from ground on a 54" bed height while empty at 70° F is approximately 7-12 seconds.	
Cause	Correction
a. Low hydraulic fluid	Make sure the reservoir has the proper amount of fluid. The hydraulic fluid should be within ½ " of the top of the reservoir with the liftgate in the lowered position. Fill with Dexron III automatic transmission fluid or other acceptable fluid (see Hydraulic Fluid Chart in "Maintenance Guide" section of this manual). Low fluid levels can introduce air, which will compress, especially when loaded and can make the liftgate feel "spongy". It can also make the gate raise at varying and alternating speeds (i.e. slower as the air is compressed, then suddenly quicker as the air expands in a repeating pattern).
b. Cold Weather	Refer to Hydraulic Fluid Chart in "Maintenance Guide" section of this manual, for alternative oils to use for cold weather conditions
c. Overload condition	The power unit on M is equipped with a lifting relief valve to prevent overloading of the liftgate while attempting to raise a load. See relief setting in "Maintenance Guide" section of this manual. Do NOT overload the liftgate.
d. Low voltage and/or bad ground	If the voltage reaching the motor drops below 10V under max. load conditions, this low voltage can cause the liftgate to slow. If voltages get low enough or ground is inadequate, the liftgate may not raise at all (see Problem 1) and will not be able to develop the rated relief pressure. Low voltages can cause motor start solenoids to overheat and internally weld the contacts closed, which can lead to motor overheating and pump failure. DO NOT run the liftgate under low voltage/and or bad ground conditions.
e. Improperly adjusted or defective main relief valve	See section "c" above for relief valve setting. Lower the gate completely to the ground to relieve all pressure from the hydraulic system and remove all loads from the platform. Plumb a pressure gauge into the high pressure circuit of the liftgate. Engage the "UP" switch until the liftgate is fully raised. Keep the "UP" switch engaged until the pump bypasses through the relief valve and note the pressure on the gauge at this time. If the rated relief pressure is not present during relief, adjust the high pressure relief valve setting as necessary. If the relief pressure is not attainable the relief valve must be cleaned and/or replaced or the pump is defective. See part i below.
f. Lift cylinder is bypassing, liftgate is drifting down too quickly	If the liftgate will not raise with a load on the platform but empty is raising slowly or only partially, the cylinder may be bypassing. A bypassing cylinder will cause increased hydraulic drift in the liftgate. To check for a bypassing cylinder do the following. Lower the gate to the ground to relieve all pressure from the cylinder. Disconnect the cylinder from the liftarm. Press the "RAISE" switch until the cylinder is fully retracted. Disconnect the return line from the power unit and put the end of the line in a container to catch any oil which comes out during this test. Press the "RAISE" switch for 15 to 20 seconds and watch for a steady stream of fluid coming out of the return line into the container. If no steady stream of oil is present connect the hose to the butt end of the cylinder after removing the return line and fitting. Attach the return line and fitting to the rod end port. Put the loose end of the return line in a container to catch any oil, which comes out during this test. Press the "RAISE" switch until both cylinders are fully extended. Press the "RAISE" switch for 15 to 20 seconds and watch for a steady stream of fluid coming out the return line in the container. Replace or rebuild any cylinder with fluid coming out of the return line, as this indicates fluid is bypassing the piston seals on the cylinder. Reconnect rebuilt or replaced cylinders and hoses as before.
g. Broken hydraulic line	Broken or punctured hydraulic lines and fittings must be replaced with care to avoid injury from high pressure oil streams.
h. Clogged or disconnected suction line	With the liftgate at the ground, disconnect the power unit and remove the reservoir. Check to see if the suction tube is clogged or has fallen out of the pump base. Clean the screen or reattach the suction tube as required.
i. Defective pump	If all else fails, the power unit MAY be defective. If the liftgate is older, the pump may be worn out and unable to pump fluid at pressure with the correct flow rate. Feel free to contact Thieman for further consultation.

<b>3. Problem - Liftgate will not lower</b>	
<b>Cause</b>	<b>Correction</b>
a. Defective lowering solenoid coil or valve	With the “DOWN” switch engaged check for voltage on the green wire at the switch. If no voltage is present replace the switch. If voltage is present, with the “DOWN” switch engaged, check for voltage at the green wire on the lower solenoid valve coil terminal. If no voltage is present, the green wire from the “DOWN” switch is loose or broken and needs replaced. Check for proper ground at the purple wire on the lowering solenoid coil. Repair or replace ground as required. If there is voltage (minimum of 9.5 volts) and proper ground at the lowering coil, and the valve is not opening to allow the gate to lower, either the lower coil is bad or the entire lower coil/valve assembly is bad. To check to see if the coil is defective, remove the green and purple wires from the spade terminals on the lower coil and check the resistance between these spade terminals (3.6 - 4.4 Ohm acceptable). ). Note: Low resistance can cause the 20 fuse to blow (see Problem 1, part b) and high resistance will lower the coils magnetic force and may not shift the valve. If proper resistance does not exist, replace the defective coil, otherwise replace the defective lower coil/valve assembly
b. Clogged or defective hydraulic lines, fittings or flow controls	Remove any obstruction in the hoses, fittings or flow controls or replace any hose, fitting or flow control, which does not allow fluid to flow through freely.
<b>4. Problem – Oil or foamy oil/air mixture flowing from reservoir breather</b>	
<b>Cause</b>	<b>Correction</b>
a. Air is present in the system	This can occur if the motor is not running as the liftgate is lowered. See Problem 1, part f and g. Also air can enter the system if the fluid level is low, see Problem 2, part a, or if the suction tube is disconnected, see problem 2, part j. Also air may enter through fittings, which are not tightened properly, so check for any leaks around fittings or hoses. Once the source of the air is determined, the cylinders must be bled of all air. Most air can be removed from the system by lowering the gate to the ground to relieve all pressure from the cylinders, unpinning the cylinders and cycling them back and forth several times from fully extended to fully retracted and allowing the pump to bypass through the relief valves for a few seconds in each direction.
b. Flow control is on backwards, <b>gate lowers too fast</b>	The flow control provided is rated at 1.5GPM or 3.0 GPM. The arrow on the flow control must point away from the cylinder, designating the direction of the controlled flow. Flow controls with improper arrow orientation, will cause the gate to lower too quickly. Correct as needed.
c. Inoperable flow control, <b>gate lowers too fast</b>	Inoperable flow controls can cause the gate to lower too quickly. Remove and disassemble the flow control and check for excessive wear and contamination. Clean as needed and reassemble. Replace the flow control if necessary.
d. Reservoir was overfilled or filled with liftgate in wrong position.	See the <b>MONTHLY INSPECTION AND MAINTENANCE</b> in the “Maintenance Guide” section of this manual to find out what position the liftgate should be in when checking the reservoir level and how full the reservoir should be in that position.
<b>5. Problem – Platform difficult to unfold to horizontal position, after lowering gate from stored position OR platform hard to fold up from horizontal position</b>	
<b>Cause</b>	<b>Correction</b>
a. Platform pivot pins are seizing up in platform lugs.	Check that the platform pivot pins turn freely in the platform lugs. Any tightness in these lugs will result in additional force required when folding or unfolding the platform.

b. Worn out platform springs or springs which are not properly lubricated	If the platform pivot pins turn freely in the platform pivots, but the platform is still hard to fold from the horizontal to vertical position, one or both of the coiled torsion springs on the platform may be weak or broken. Replace any springs which are broken or which are permanently deformed and do not return to the same position as a new spring. Alternately, the springs on the platform may need lubrication. Under the "Maintenance Guide" section of this manual, there are instructions for periodic lubrication, which includes lubrication across the coils of the platform springs. This allows the coils to slide past each other as the torsion spring is loaded and the coils rotate. Springs that are not lubricated, can make the platform harder to fold.
---	--

If you have any questions or problems that are not covered in this guide please call Thieman's Engineering Department at 1 800-524-5210.



